

INSTRUCTION MANUAL FOR FLOW SWITCHES PL SERIES

1. INSTRUMENT DESCRIPTION

Flow switches PL series are designed to be mounted in an upright position along horizontal pipes.

These models are equipped with a tripping device, which can be equipped with single (SPDT) or double (DPDT) exchange contacts for high or low flow rate control and/or alarms.

2. MODEL IDENTIFICATION

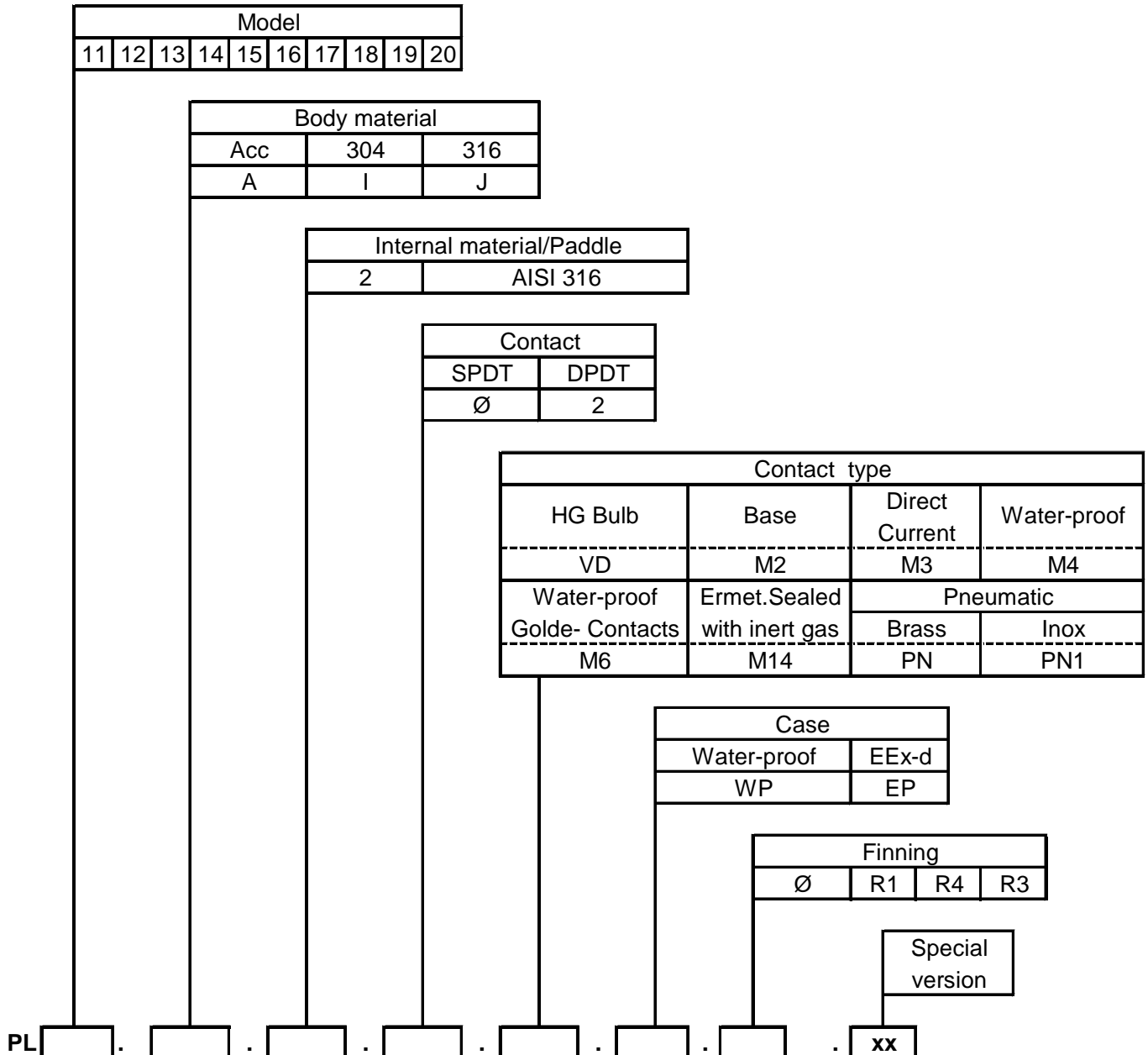

3. OPERATING PRINCIPLE

To the paddle(1), which is soaked in the fluid, through a rod, a small piston (2) made from magnetic stainless steel is connected; this small piston is housed in a pit (3) made from non-magnetic material.

On the pit (3) a tripping device, which is drawn schematically beside, is mounted. It is composed of a magnet (4) and a miniature switch (5) that are connected to one another by means of levers.

In low flow-rate conditions (fig.“A”), the magnet (4) is at rest, whereas in high flow-rate conditions (fig.“B”), the magnet (4) is attracted by the small piston (2) that causes the miniature switch (5) to operate.

The difference between high and low flow-rate is called “tripping differential”.

The arrow indicates the direction fo the flow.

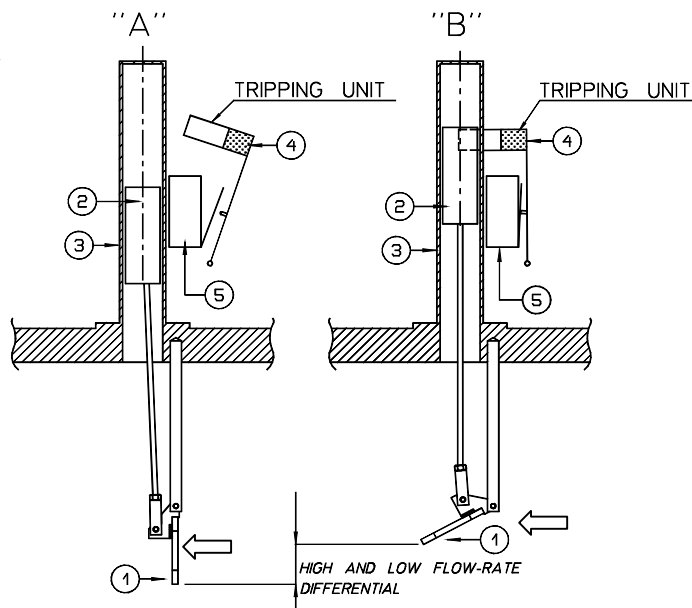

4. INSTALLATION

4.1 INSTALLATION ON THE SYSTEM

Before installation, check the line connections for compatibility with the instrument connections.

The flow switch shall be installed in a perfectly upright position and the piping shall be straightaway for at least 5D upstream and 3D downstream.

The flow switch body has an arrow indicating the direction taken by the flow; comply with such indication at the assembling stage.

Remove the adhesive tape that locks the paddle and the plastic strip inserted in the tube, so that the stem becomes free to move. Ensure that the entire paddle is inside the piping and that, at rest (no fluid), it does not touch the bottom of the piping.

It is strictly prohibited to load the instrument with external loads and it is the user’s duty to protect it from strain; do not use it as resting point.

To avoid effects of galvanic corrosion, any use of materials featuring a different electrochemical potential is prohibited. The user shall adopt all those technical devices that can prevent this event from occurring.

The system shall be equipped with the specified technical device, to make up for overpressure going beyond the maximum envisaged point.

For installation on piping exposed to strong vibration, please contact the Customer service department.

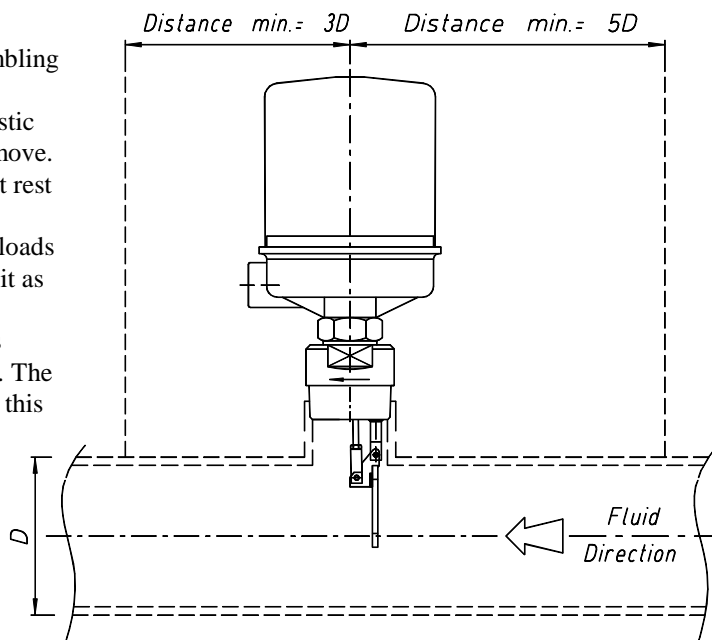

4.2 WIRING

The flow switch has a terminal board inside the case for NC - C - NO connections (see figure on the right).

Make sure that the cover of the housing is closed properly before powering up.

The user shall provide suitable ground connections that are such as to protect the staff and any other equipment possibly present.

The NC-NO condition referred to herein is with null fluid.

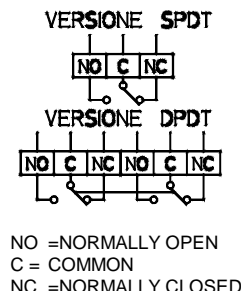



5. SETTING AT WORK

Make sure that the use of the instrument does not exceed the intended conditions of use (higher temperature and pressure values, lower flow rates) and that the applied electrical rating value complies with the rating plate values. Verify that the instrument operates a correct switchover, by making the fluid flow rate vary a few times.

6. CALIBRATION

The unit is not generally **factory-set, hence it demands** on-site setting.
(See maintenance, operation point setting paragraphs).

7. MAINTENANCE

We recommend inspecting the flow switch on a routine basis (every 6 months or so) to guarantee full efficiency. All maintenance activities shall be performed when the instrument is off, not under pressure and emptied of its fluid, at room temperature (in the event of instruments working at high or low temperature) and free from the contact's feeding voltage.

7.1 WARNINGS

- NEVER open the cover of the case before the power supply has been cut off;
- NEVER leave the case without its cover for more than the time absolutely necessary for the inspection;
- NEVER use the flow switch with pressure or temperature levels in excess of those indicated on the ratings plate;
- NEVER use the flow switch with mains voltage in excess of that indicated on the ratings plate;
- NEVER adjust or replace any components without having first read the relevant instructions carefully. If in doubt, contact our Customer Services;
- NEVER lubricate instrument components;
- If being used with high temperatures, adopt all the relevant precautions to guarantee that service personnel are protected during maintenance operations.

7.2 PADDLE ROUTINE INSPECTION

Ensure the device is disconnected from the system and with all the fluid already drained out.

- Disconnect the voltage supply;
- Dismount the device from the piping by lifting the upper flange of the body or by unscrewing the union (take care not to spoil or damage the rod and paddle);
- Inspect the piping and check it is clean from incrustation and/or deposit (if any such deposits are found, perform a thorough cleaning);
- Dismount the rod assembly by removing the pin that connects the fork to the paddle and the latter to the stud bolt;
- Inspect the pit inside making sure it is free from incrustation (clean with care if necessary);
- Ensure the paddle and the rod are free from incrustation (if any are found, clean thoroughly) and do not show any marks of wear or corrosion (if necessary, replace them);
- Place the rod assembly and the paddle back in place carefully;
- Manually lift and lower the paddle to ensure the whole set slides freely;
- Ensure the switching unit trips when the paddle is in the high flow-rate position.

7.3 REPLACING THE PADDLE

After dismantling the old paddle (see par.7.2), fit the new one and perform all the checks as detailed in par. 7.2.

7.4 ROUTINE INSPECTION OF THE CONTACTS

Cut off the power supply.

Open the cover and visually check that the tripping unit is not damaged or worn. Manually move the magnet and check that the micro-switch trips properly.

7.5 REPLACING THE UNIT AND/OR MICRO-SWITCH

- a - use a gauge to measure the position of the switch unit;
- b - disconnect the wires from the terminal board (make a note of the original connections) and remove the switch unit by loosening the screw (2);
- c -replace the micro-switch (1);
- d -return the switch unit in the pit (3) in exactly the same position as before;
- e-adjust the tripping position by manually moving the magnet (4) against the pit (3), tighten grub screw (5) until the micro-switch trips and allow for one extra turn before locking the grub screw;
- f - check that the micro-switch (1) works efficiently using an ohmmeter and a few manual tripping checks;
- g - reconnect the wires to the terminal board as per point b.

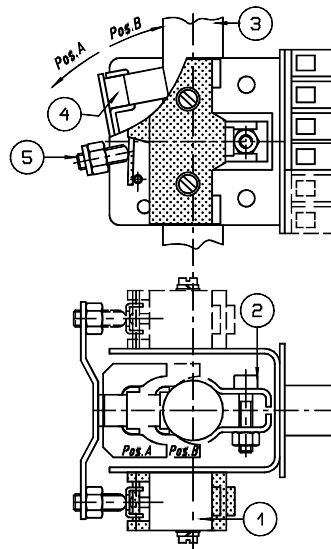
7.6 SETTING THE OPERATION POINT

- The switching unit is factoryt-set to the minimum operation value.
- To set the operation point to the desired flow rate value, take the following steps:
 - a -place the switching unit on the top of the pit (3) by loosening screw (2);
 - b -adjust the fluid to the desired flow rate;
 - c -slowly lower the switching unit until the switching takes place (from pos. "A" to pos. "B");

If the requested alarm is a high flow-rate one, you can lock the switching unit, if it is a low flow-rate one, slowly lift the switching unit until the magnet (4) returns to pos. "A" and lock it in this position by means of screw (2).

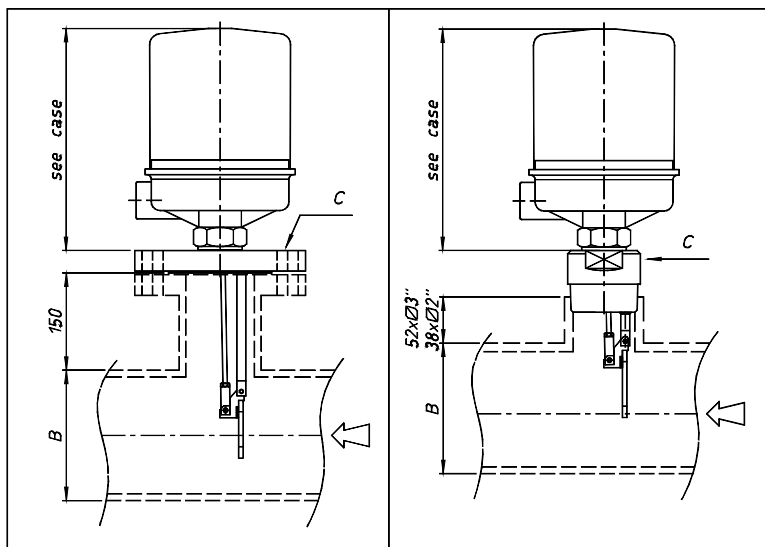
8. DIMENSIONAL DRAWINGS OF THE BODY

MODELLO MODEL	ØB MIN.	SET m/s (Low flow)	FLUIDO FLUID
PL11	6" sch.40	0.1 - 0.6	WATER
PL12	4" sch.40	0.4 - 0.9	WATER
PL13	4" sch.40	0.4 - 1.0	WATER
PL14	4" sch.40	1.1 - 2.7	WATER
PL15	6" sch.40	4.0 - 7.0	AIR
PL16	4" sch.40	0.3 - 0.7	WATER
PL17	3" sch.40	0.4 - 0.9	WATER
PL18	3" sch.40	0.7 - 1.4	WATER
PL19	4" sch.40	1.2 - 2.4	WATER
PL20	6" sch.40	4.5 - 8.0	AIR

RESET point :+25% from the Set

Dimensional values demanded in the order:

- B** = Pipe
- C** = Connections

9. DRAWINGS OF CASE WITH DIMENSIONS

CODE	LIQUID TEMPERATURE
Ø	-10÷+135
R3	-11÷-80
R1	+136÷+250
R4	+251÷+400

ELECTRICAL CONNECTIONS Ø A	
EP	WP
1/2" NPT	1/2" NPT
3/4" NPT	3/4" NPT
1/2" UNI 6125	1/2" (GAS) ISO 228/1
3/4" UNI 6125	3/4" (GAS) ISO 228/1
ISO M20 x 1.5	1/2" UNI 6125
	ISO M20 x 1.5

EP CASE (EEx-d IIC T6)

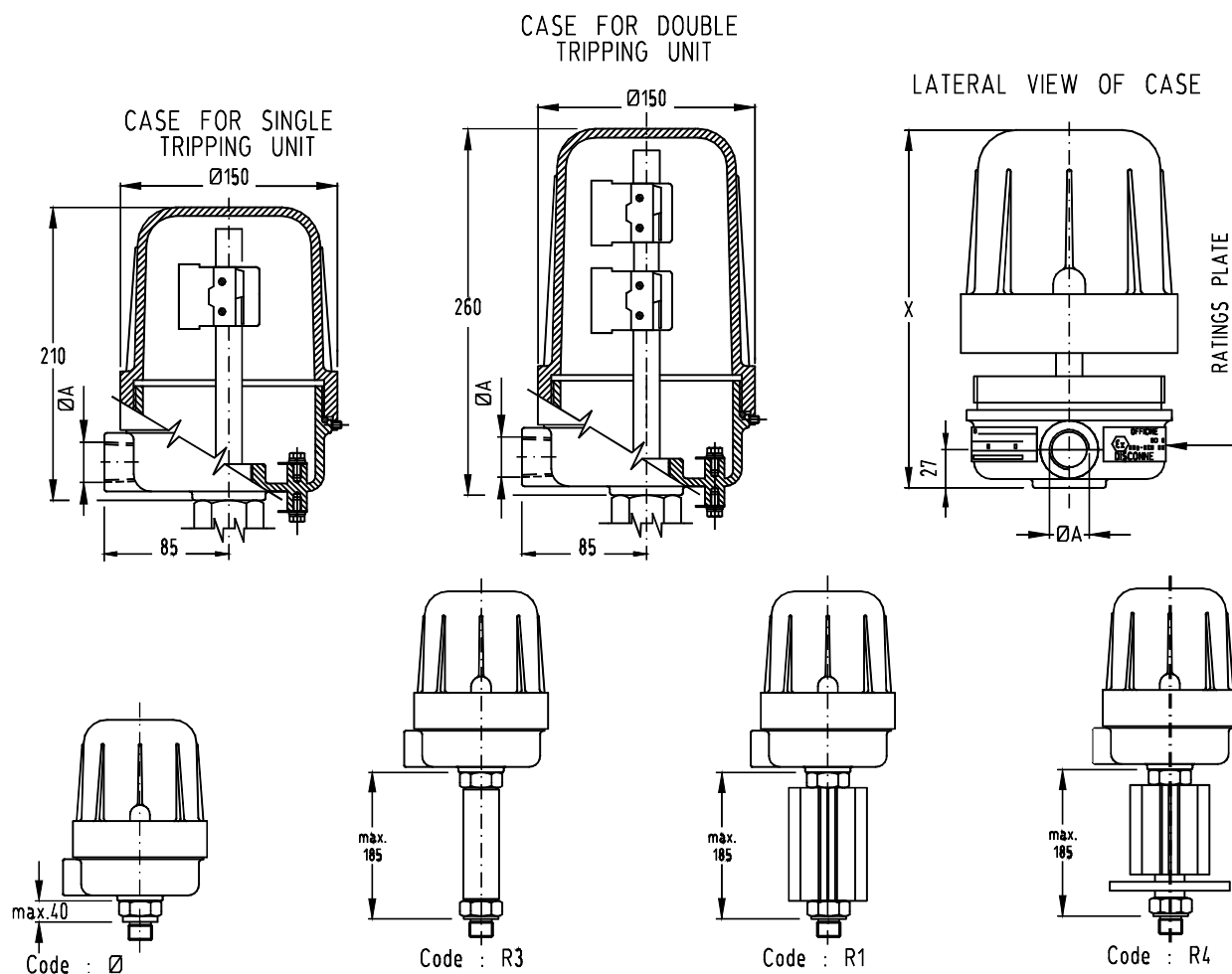

SPACE NEEDED FOR REMOVING THE CASE COVER: X =340
X =440

CASE WITH SINGLE TRIPPING UNIT
CASE WITH DOUBLE TRIPPING UNIT

WP CASE (WATER PROOF IP 66)

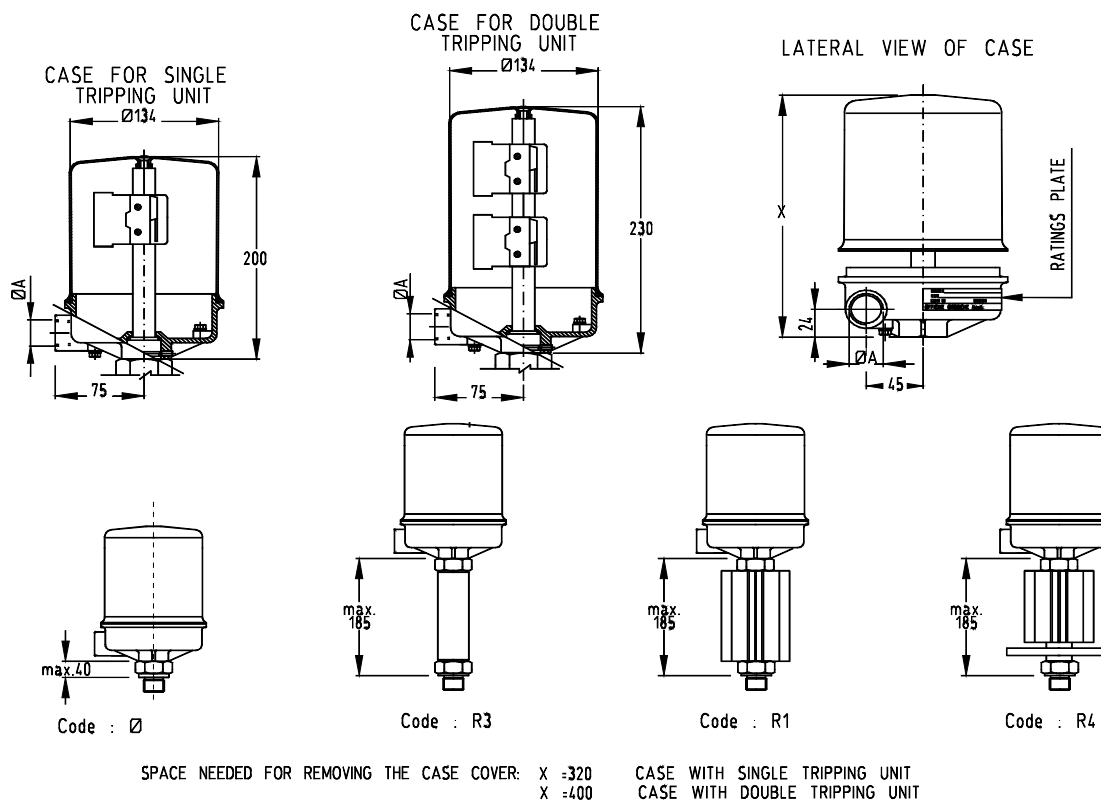

10. RECOMMENDED SPARE PARTS (*)

POS.	DENOMINATION
1	BODY FLANGE
2	STUD BOLT
(x) 3	PADDLE
4	ROD ASSEMBLY
(x) 5	UNION GASKET
6	UNION
(x) 7	SWITCH UNIT
(x) 8	MICROSWITCHES
9	INSTRUMENT RATING PLATE
10	EXTERNAL GROUND UNIT
11	INTERNAL GROUND UNIT
(x) 12	GASKET CASE
13	CASE BASE
14	CASE COVER
15	GROUP SCREWS FIXING COVER TO CASE TYPE EP
16	GROUP SCREWS FIXING BASE TO CASE TYPE WP
17	GROUP SCREWS FIXING COVER TO CASE TYPE WP

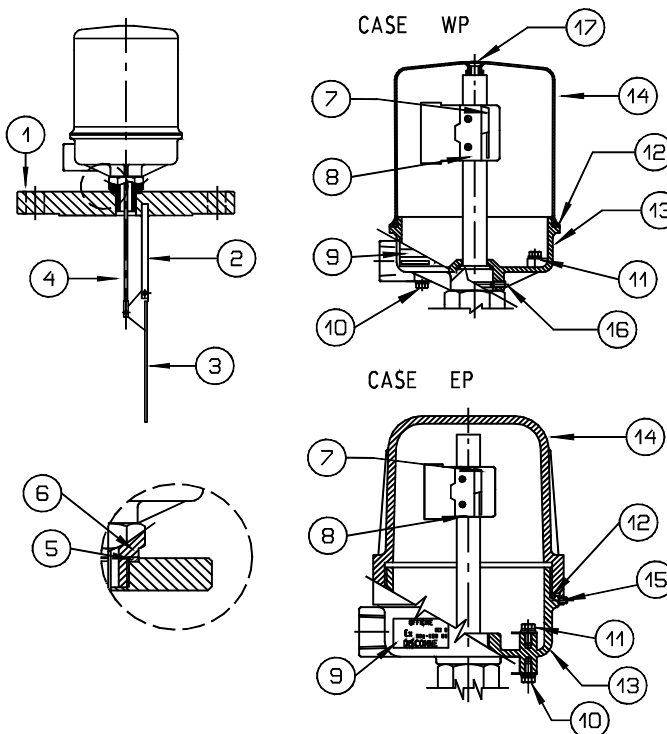

When ordering spare parts, always indicate the instrument's serial number.

You can find it on the ratings plate on the case (see Pos.9) and has 5 digits preceded by the letter "F" (e.g.: F45678).



11. TROUBLESHOOTING

Flow switches of the PL series are not normally subject to faults.

In cases when the flow switch does not operate the switching, please carry out a test procedure as per paragraph 7. MAINTENANCE.

12. DISPOSAL

Once the flow switches have reached the end of their working life, they should be sent for disposal in accordance with prevailing regulations.

During their disposal, pay special attention to the polymers, resins and rubber used in their construction (PVC, PTFE, PP, PVDF, neoprene, viton etc.).

Metal components may be recycled after removing the gaskets, special coverings as requested by the customer or other plastic materials.

WARNING:

If mercury bulb micro-switches (code VD) have been installed, they must be disposed of in accordance with prevailing regulations concerning toxic substances; the other types of micro-switch are not subjected to these regulations.

13. WARRANTY

All series PL Flow switches are guaranteed against manufacturer defects for a period of 12 months from the date of shipment.

In the event of a malfunction, if the defective part is returned within the above-mentioned warranty period, Officine Orobiche undertakes to replace any damaged parts under warranty (excluding transport costs), provided that the defect is not the result of the improper use of the instrument.

Officine Orobiche may not be held liable for any improper use of its products where these are used for ends other than those indicated in the specifications forming part of the order.

No claims for damages will be accepted in the case of improper use.

Damages and/or expenses, whether direct or indirect, arising from improper installation or use of the instrument shall not be attributable or debited to Officine Orobiche under any circumstance.

The instrument may be used for a maximum period of 10 years from the date of delivery.

After said period, the customer has two alternatives:

- 1) Replace the instrument with a new one.
- 2) Have the instrument overhauled by Officine Orobiche

HOW TO RETURN INSTRUMENTS

Any returned instruments must be accompanied by a sheet indicating:

- 1) The name of the customer
- 2) A description of the material
- 3) Details of the fault
- 4) Process data
- 5) Liquids with which the instrument has come into contact

The returned instrument must be perfectly clean, free of dust and deposits; otherwise, Officine Orobiche may reserve the right to refuse to carry out the required maintenance and return the item "as found" to the customer.

FINAL NOTES

Every instrument is supplied fully assembled with all the accessories requested by the customer.

Only in exceptional cases will the various components be supplied separately.

We therefore recommend that the customer inspects the delivery on arrival and immediately notifies Officine Orobiche of any discrepancies.

N.B. IN CASES WHEN THE INSTRUMENTS ARE MEANT TO BE USED IN AREAS FEATURING POTENTIALLY EXPLOSIVE ATMOSPHERES, THE USER SHALL COMPLY WITH THE ADDITIONAL SAFETY INSTRUCTIONS ATTACHED TO THE STANDARD ONES.