



**INSTRUCTION MANUAL FOR VISUAL FLOW INDICATORS
SERIES IVF**

1. INSTRUMENT DESCRIPTION

Visual flow indicators are normally used to display the passage of liquids; moreover, there are models that are even pre-arranged to sense gaseous fluids.

Visual flow indicators of the free-passage type are designed to be fitted in whatever position within the system, both vertically and horizontally, and with a two-directional flow.

- “model **SLE**”: free-passage sight glass;
- “model **SCE**”: free-passage sight glass with chain to further improve the fluid passage display.
- “model **SBE**”: free-passage sight glass with fixed paddle to create whirlpools within the flow and further improve the flow passage display;
- “model **SBB**”: free-passage sight glass with drip for a typical application within distillation processes;
- “model **SSC**”: free-passage sight glass with glass tube;
- “model **SPG**”: free-passage sight glass with threaded ring nuts;
- “model **SPV**”: free-passage sight glass with rotating impeller.

As regards visual flow indicators of the moving paddle type, the direction and the sense of the flow are well known and shall always be respected.

- “model **SPA**”: sight glass of the moving paddle type for vertical mounting with ascending fluid;
- “model **SPD**”: sight glass of the moving paddle type for vertical mounting with descending fluid;
- “model **SPO**”: sight glass of the moving paddle type for horizontal mounting with fluid rate measurement.

There are another two types of sight glass that are used as visual windows for mounting on vessels:

- “model **SSR**”: with circular-shaped;
- “model **SSL**”: with oval-shaped.

Finally, there are also two models in which display of passage to liquids, isn't carried on directly from the porthole, but through a returned indicator (these two models are suitable for high pressures and/or temperature):

- “model **CV-TM**”: sight glass with valve type body;
- “model **SPO-TM**”: sight glass with body “SPO” model.

2. MODEL IDENTIFICATION

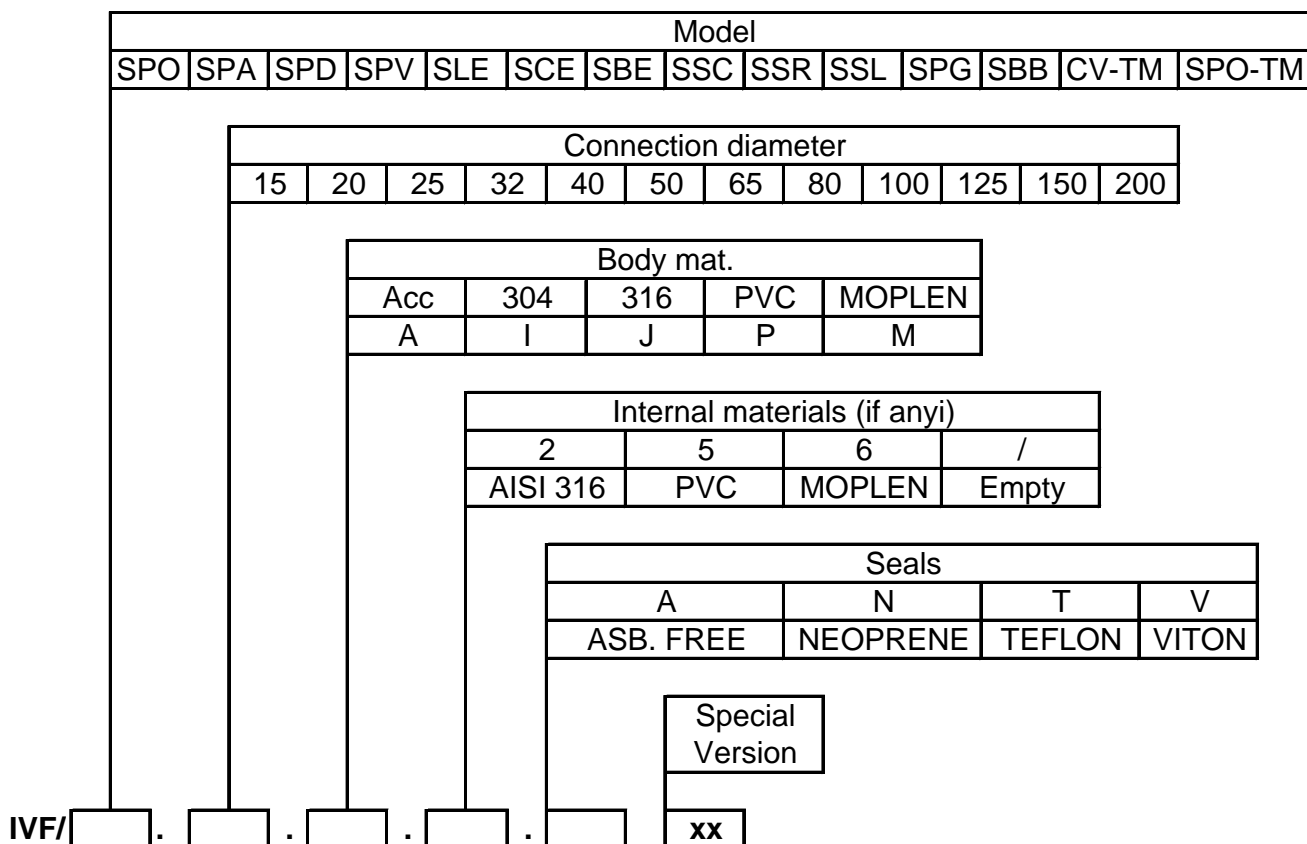

3. OPERATING PRINCIPLE

The operating principle is based on the fluid passing through the instrument and its display through a transparent porthole (e.g. made from glass), or is made with the returned indicator.

This passage can be further displayed with paddles (fixed or moving)), chain and drips.

In model SPO, the paddle indicates the flow rate on a graduated scale that is silk-screen printed on the porthole.

4. INSTALLATION

4.1 INSTALLING THE INSTRUMENT

Before installation, check the line connections and the instrument connections for compatibility.

As regards the SPO model, the unit shall be installed in a perfectly horizontal position and the piping shall be rectilinear for at least 5D (D= inner diameter of the piping) upstream and 3D downstream. Remove the piece of cardboard (if any) that blocks the paddle.

In cases when the instrument shows an arrow that indicates the direction of the flow, please comply with that indication at the assembling stage. Moreover, if the passage fluid is at high temperature or very cold, the user shall adopt insulation/protections that are able to minimize all differences in temperature from room temperature.

Burdening the unit with external loads is strictly prohibited and it is the user's duty to protect it from whatever stress; all use as a point of support is not allowed.

To avoid all effects of galvanic corrosion, never use materials featuring a different electrochemical potential, the user shall take all actions that are aimed at preventing such condition for the unit.

The system shall be equipped with the prescribed safety valve, to remedy over pressure values that exceed the maximum value. For installation on piping exposed to strong vibration, please contact the customer service department.

4.2 INSTALLATION IN AREAS OF SPECIAL CONCERN

In cases when the units are installed in Areas that feature the presence of potentially explosive atmospheres, the user shall stick to the **additional safety instructions** attached to the standard instructions.



5. SETTING AT WORK

Ensure that the use of the instrument does not range out of the admitted ones, with higher pressure and temperature values and lower flow rates.

The user shall absolutely avoid the occurrence of the so-called “water hammers”, taking care to always start the fluid in a gradual manner.

6. CALIBRATION

The instrument is factory-set and does not require any calibration to be performed.

7. MAINTENANCE

Owing to their constructional simplicity and the remarkable mechanical sturdiness, these instruments do not require any routine maintenance.

At all events, it is however advisable to check, every now and then, the service state of the seals and the integrity of glass discs or tubes. Ensure there is no fluid leaking out of the seals and that the porthole does not show marks of erosion/corrosion (a possible sign of corrosion is the dulling of the glass), scratches (= 0.5 mm in depth) or marks of fracture.

If necessary, immediately replace the glass and its gaskets.

These checks shall be made without dismantling the glass component from the porthole flange.

In cases when, no matter why, the user decides to dismantle the glass components, the latter and the dismantled seals, even if they do not show any deep mark of failure or wear, shall never be put back in place; they will need to be replaced with new parts.

The SPO series requires an additional check on the moving paddle (see Par. 7.2 below).

All maintenance activities shall take place when the unit is disconnected from the system, without pressure and fluid, and at room temperature (in the vent of instruments that work at high or low temperature).

7.1 NOTICES

- NEVER use the unit with a pressure or temperature value that exceeds the rating data;
- NEVER make adjustments or replace parts without having first carefully read the relevant instructions; in case of doubts, please consult our customer service department;
- NEVER lubricate parts of the instrument;
- In cases when the instrument is used with high temperatures, please take all measures required to safeguard and protect the service staff at all maintenance stages.

7.2 ROUTINE CHECK OVER THE MOVING PADDLE (for model SPO)

Ensure the instrument is disconnected from the system, with no fluid left inside.

- Dismount the instrument from the piping;
- Inspect the piping and ensure it is free from fouling and or deposits (if necessary, clean carefully);
- Ensure the paddle is free from fouling (if necessary, clean carefully) and does not show wear or corrosion marks (replace if these can be found);
- Carefully reassemble the instrument on the piping.

7.3 TIGHTENING

The edge of the glass shall not lie against the edges of the porthole flanges, whereas there must be a space of at least 1 mm between the glass and its seating (to compensate for all thermal expansion possibly occurring).

Unless specifically instructed otherwise, the tightening pressure of the bolts on the glass flange should range between 2 and 2.8 times the maximum admitted pressure, approximately.

The tightening shall occur in a gradual manner and in such a way as to avoid excessive local stress.

Tighten the tie rods in a sequence, in at least two subsequent stages.

8. DIMENSIONAL DRAWINGS OF THE BODY

The typical dimensions are specified on the several technical reports and, as regards models that are not listed (special embodiments) a special dimensional drawing is provided.



9. RECOMMENDED SPARE PARTS

The recommended spare parts are:

- Glass components
- Seals

In ordering spare parts, please always mention the unit's serial number.

This number can be found on the rating plate of the instrument, which can be found on the housing, and is a number composed of five digits which are preceded by the letter "F" (e.g.:F45678).

10. TROUBLESHOOTING

Visual flow indicators are not normally subject to operating failures; in the event of an operating failures, please refer to paragraph 7 MAINTENANCE, or contact our Customer Service department.

11. DISPOSAL

When the instruments have come to the end of their service life, they need to undergo disposal.

Always comply with the applicable regulations in force.

During the disposal stages, specially mind the polymers, resins and rubbers used in the manufacture (such as PVC, PTFE, PP, PVDF, neoprene, viton, etc.).

All metal parts, after the removal of seals and gaskets, special protective coatings requested by the customer and all other plastic parts, can be recycled.

12. GUARANTEE

All visual flow indicators are guaranteed to be free from manufacturing faults over a period of 12 months from the date of shipment.

In the event of failures, implying return of goods within the limit specified above, OFFICINE OROBICHE will replace (shipment fees not included) all damaged parts free, provided that the failure does not ensue from incorrect use.

OFFICINE OROBICHE shall never be held responsible for any incorrect use of their products when these are used for purposes other than those mentioned in the specifications approved at the order stage.

In these cases, no complaints will ever be taken into consideration.

No damage and/or fee, whether direct or indirect, ensuing from an incorrect installation or use shall ever be debited to OFFICINE OROBICHE.

The instrument can be used for a maximum life period of 10 years dating from delivery.

When this period is over, there are two alternative options:

- 1) Replace it with a new instrument.
- 2) Have the old instrument overhauled by OFFICINE OROBICHE.

INSTRUMENT RETURN PROCEDURE

The instrument returning to the factory shall bear, in attachment, the following data:

- 1) Buyer's name.
- 2) Description of the material.
- 3) Detected fault.
- 4) Process data.
- 5) Specification of the fluids that have been used with the instrument.

The instrument shall be returned perfectly clean and free from dust or deposits. Otherwise, OFFICINE OROBICHE reserves the right not to carry out the servicing and return the instrument to the sender.

FINAL REMARKS

Each instrument is supplied fully assembled and equipped with all the needed accessories.

Some parts are sold separately under special circumstances only.

Therefore, we warn you to carefully inspect the supply and notify us at once if discrepancies are found.

N.B. IN CASES WHEN THE INSTRUMENTS ARE MEANT TO BE USED IN AREAS FEATURING POTENTIALLY EXPLOSIVE ATMOSPHERES, THE USER SHALL COMPLY WITH THE ADDITIONAL SAFETY INSTRUCTIONS ATTACHED TO THE STANDARD ONES.