



INSTRUCTION MANUAL FOR LEVEL SWITCHES SERIES 60 Electric

1. INSTRUMENT DESCRIPTION

Series 60 level switches have been designed for external lateral installation on pressure tanks in a vertical position. The models have one or two tripping units, each of which can be fitted with single (SPDT) or double exchange contacts (DPDT) for low/high level controls and/or alarms.

2. MODEL IDENTIFICATION

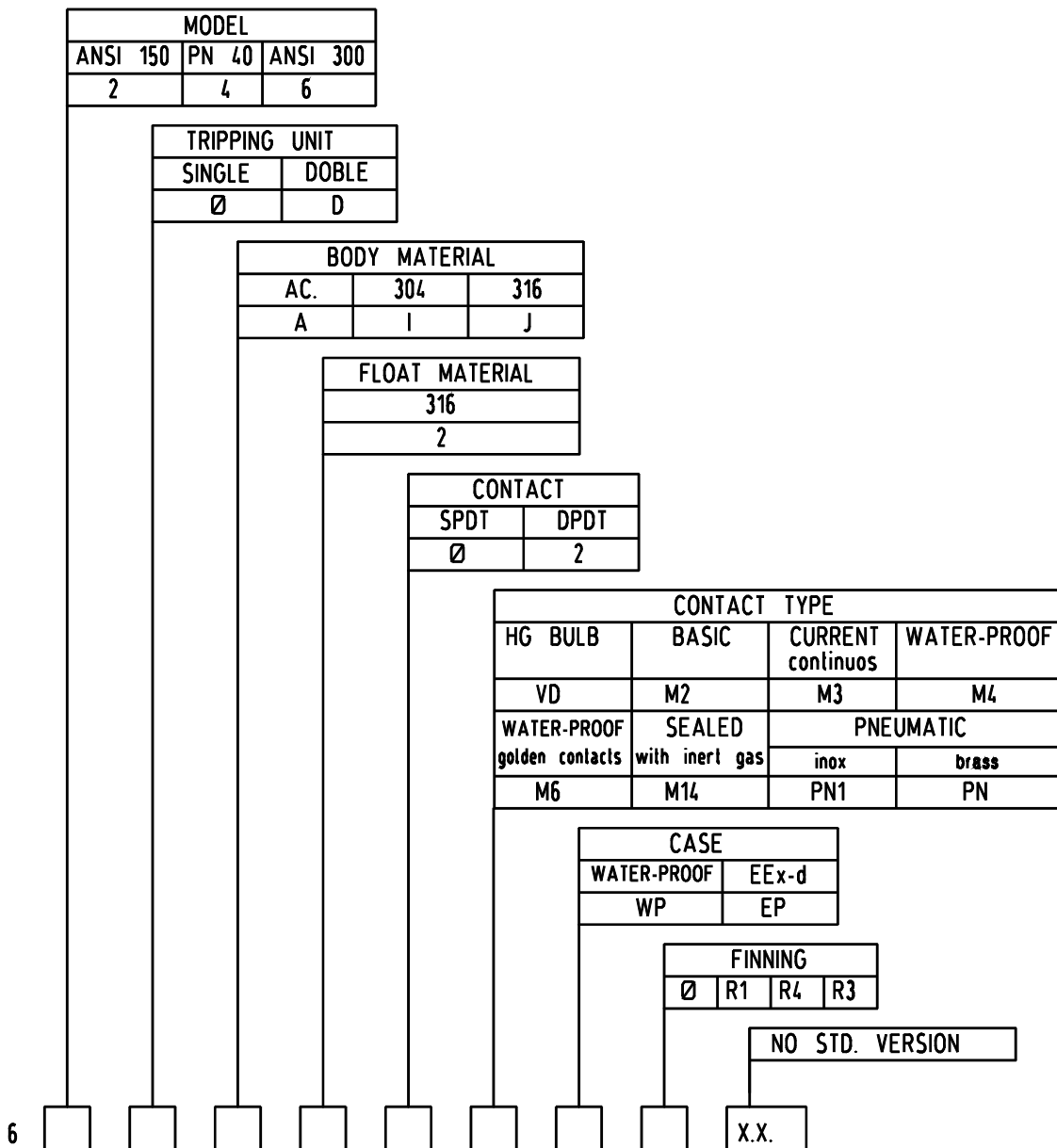

3. OPERATING PRINCIPLE

The operating principle is based on the hydrostatic principle (ARCHIMEDES' law).

The float (1) that indicates the level of the liquid is connected via a rod to a small piston (2) in magnetic stainless steel within a non-magnetic sump (3).

This sump (3) is fitted with a tripping unit (see figure) consisting of a magnet (4) and a micro-switch (5) which are interconnected by means of levers.

When the level of the liquid is low "A", the magnet (4) is at rest; when the level of the liquid is high "B", the magnet (4) is attracted by the small piston (2) which causes the tripping of the micro-switch (5).

The differences in the level of the liquid between levels "A" and "B" is called "tripping difference

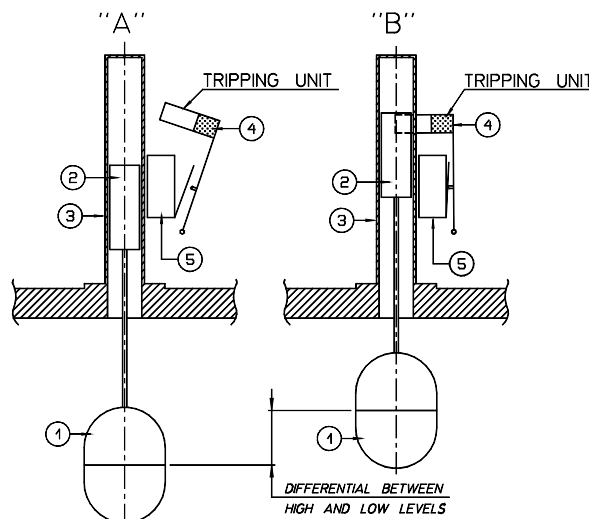

4. INSTALLATION

4.1 FITTING

Before installing the level switch, make sure that the tank and level switch connections are compatible.

It is strictly prohibited to load the instrument with external loads and it is the user's duty to protect it from strain; do not use it as resting point.

To avoid effects of galvanic corrosion, any use of materials featuring a different electrochemical potential is prohibited. The user shall adopt all those technical devices that can prevent this event from occurring.

The system shall be equipped with the specified technical device, to make up for overpressure going beyond the maximum envisaged point.

We recommend using on/off valves that allow one to remove the instrument easily and escape valves to bleed off any deposits inside the instrument.

If air or steam pockets are likely, we recommend fitting relief valves in the upper unions.

If two or more instruments need to be fitted for regulation purposes, we recommend to fit these on the pipe to which the level switch is attached.

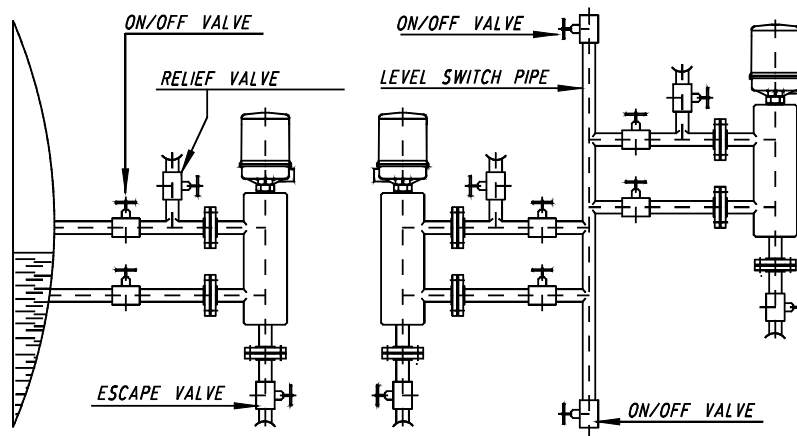

Please contact our Customer Services if the level switches have to be fitted on tanks subject to heavy vibrations

4.2 WIRING

The level switch has a terminal board inside the case for NC - C - NO connections (see figure on the right).

Make sure that the cover of the housing is closed properly before powering up.

The user shall provide suitable ground connections that are such as to protect the staff and any other equipment possibly present.

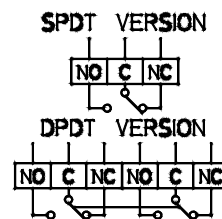

NO=NORMALI OPEN
C=COMMON
NC=NORMALI CLOSE

5. COMMISSIONING

Make sure that the expected working loads do not exceed the acceptable loads (maximum pressure and temperatures, minimum specific weight) and that the mains voltage matches that indicated on the instrument ratings plate.

Check that the instrument trips correctly by changing the level of the liquid several times.

6. CALIBRATION

The instrument has been calibrated before leaving the factory and so requires no further calibration on installation. If it needs to be adjusted, see point (Adjusting the tripping point) in the MAINTENANCE paragraph below.

7. MAINTENANCE

We recommend inspecting the level switch on a routine basis (every 6 months or so) to guarantee full efficiency. All maintenance activities shall be performed when the instrument is off, not under pressure and emptied of its fluid, at room temperature (in the event of instruments working at high or low temperature) and free from the contact's feeding voltage.

7.1 WARNINGS

- NEVER open the cover of the case before the power supply has been cut off;
- NEVER leave the case without its cover for more than the time absolutely necessary for the inspection;
- NEVER use the level switch with pressure or temperature levels in excess of those indicated on the ratings plate;
- NEVER use the level switch with mains voltage in excess of that indicated on the ratings plate;
- NEVER adjust or replace any components without having first read the relevant instructions carefully. If in doubt, contact our Customer Services;
- NEVER lubricate instrument components;
- If being used with high temperatures, adopt all the relevant precautions to guarantee that service personnel are protected during maintenance operations.

7.2 ROUTINE INSPECTION OF THE CONTACTS

Cut off the power supply.

Open the cover and visually check that the tripping unit is not damaged or worn. Manually move the magnet and check that the micro-switch trips properly.

7.3 REPLACING THE UNIT AND/OR MICRO-SWITCH

- a - use a gauge to measure the position of the switch unit;
- b - disconnect the wires from the terminal board (make a note of the original connections) and remove the switch unit by loosening the screw (2);
- c - replace the micro-switch (1);
- d - return the switch unit in the sump (3) in exactly the same position as before;
- e - adjust the tripping position by manually moving the magnet (4) against the sump (3), tighten grub screw (5) until the micro-switch trips and allow for one extra turn before locking the grub screw;
- f - check that the micro-switch (1) works efficiently using an ohmmeter and a few manual tripping checks;
- g - reconnect the wires to the terminal board as per point b.

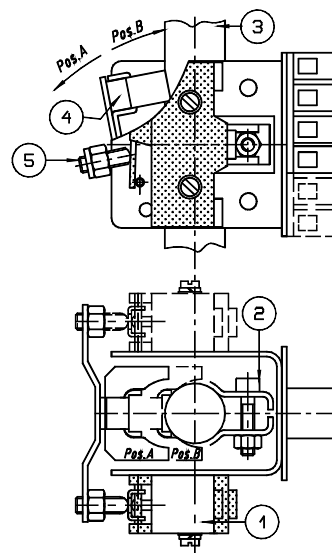

7.4 ADJUSTING THE TRIPPING POINT

-The switch unit is calibrated with a tripping point in line with customer specifications before leaving the factory; its initial position should not normally require adjusting.

-If it becomes necessary to change the default tripping point, follow these steps:

- a - take the switch unit to the top of the sump (3);
- b - top up the level of the liquid as required;
- c - slowly lower the switch unit until it trips (from pos. "A" to pos. "B").

For a high-level alarm, secure the switch unit in this position; for a low-level alarm, slowly raise the switch unit until the magnet (4) returns to pos. "A" and then secure in this position with the screw (2).

8. DRAWINGS OF BODY WITH DIMENSIONS

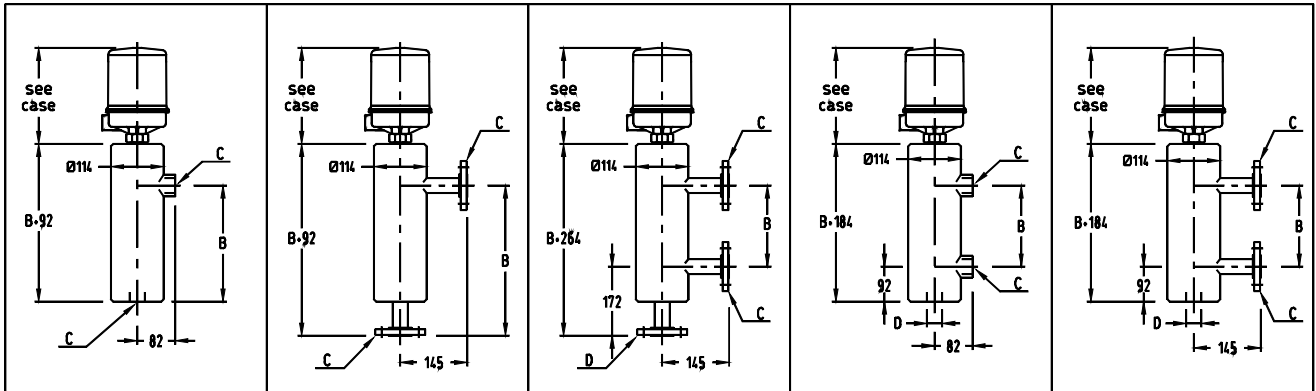

Dimensions to order

B = field **C** = connections **D** = draining

9. DRAWINGS OF CASE WITH DIMENSIONS

CODE	LIQUID TEMPERATURE
Ø	-10÷+135
R3	-11÷-80
R1	+136÷+250
R4	+251÷+400

ELECTRICAL CONNECTIONS Ø A	
EP	WP
1/2" NPT	1/2" NPT
3/4" NPT	3/4" NPT
1/2" UNI 6125	1/2" (GAS) ISO 228/1
3/4" UNI 6125	3/4" (GAS) ISO 228/1
ISO M20 x 1.5	1/2" UNI 6125
	ISO M20 x 1.5

EP CASE (EEx-d IIC T6)

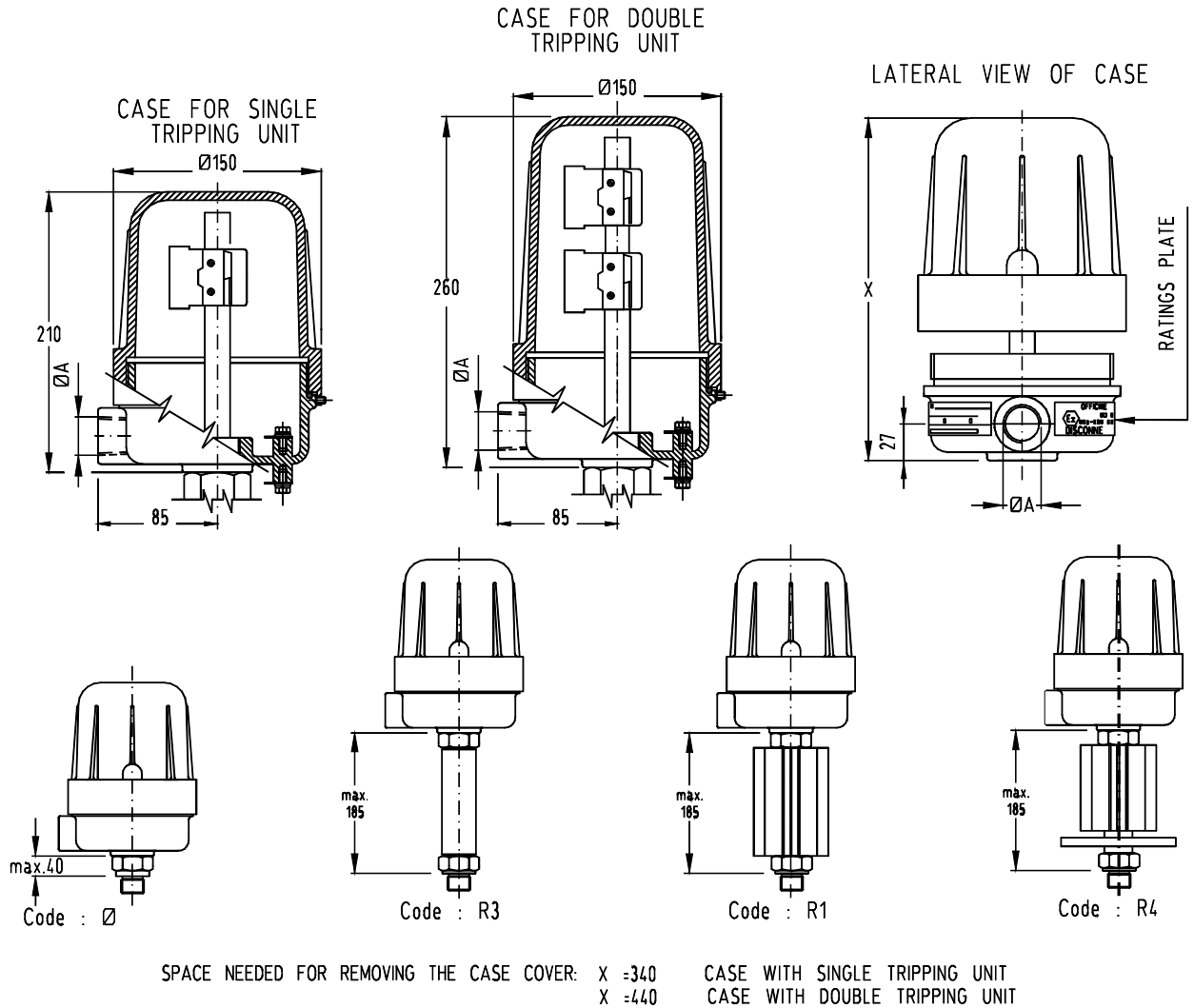

WP CASE (WATER PROOF IP 66)

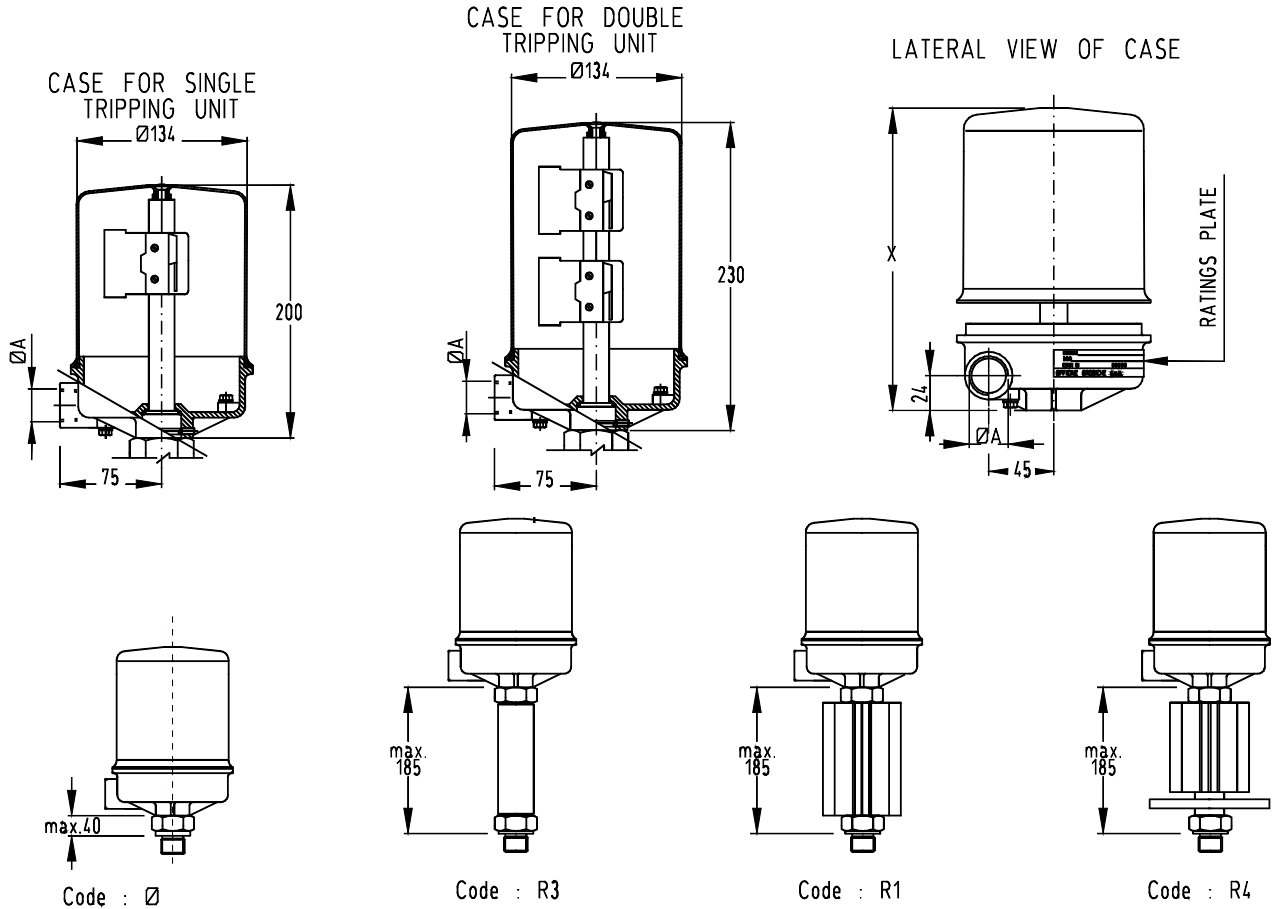

SPACE NEEDED FOR REMOVING THE CASE COVER: X = 320 CASE WITH SINGLE TRIPPING UNIT
 X = 400 CASE WITH DOUBLE TRIPPING UNIT

WP CASE (WITH CONNECTOR OUTPUT)

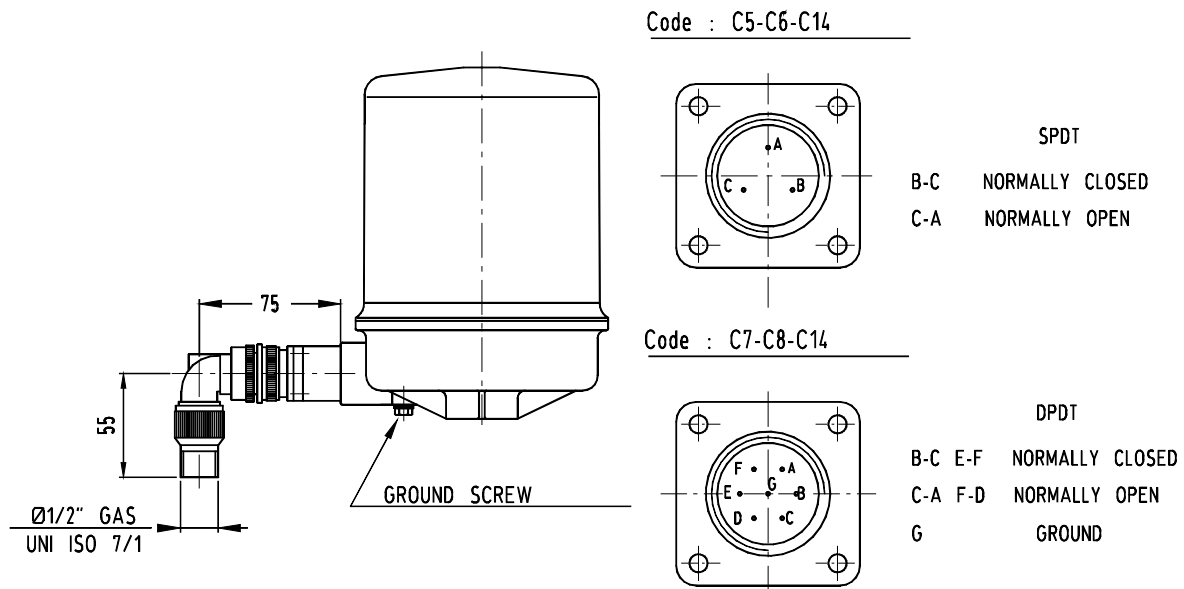

10. RECOMMENDED SPARE PARTS (*)

POS.	DENOMINATION
1	FLOAT ROD UNIT
2	BODY
3	FLOAT
4	UNION
(*)	5 GASKET
6	FLOAT STOP
(*)	7 SWITCH UNIT
(*)	8 MICROSWITCHES
9	INSTRUMENT RATING PLATE
10	EXTERNAL GROUND UNIT
11	INTERNAL GROUND UNIT
12	GASKET CASE
13	CASE BASE
(*)	14 CASE COVER
15	GROUP SCREWS FIXING BASE TO CASE TYPE EP
16	GROUP SCREWS FIXING BASE TO CASE TYPE WP
17	GROUP SCREWS FIXING COVER TO CASE TYPE WP

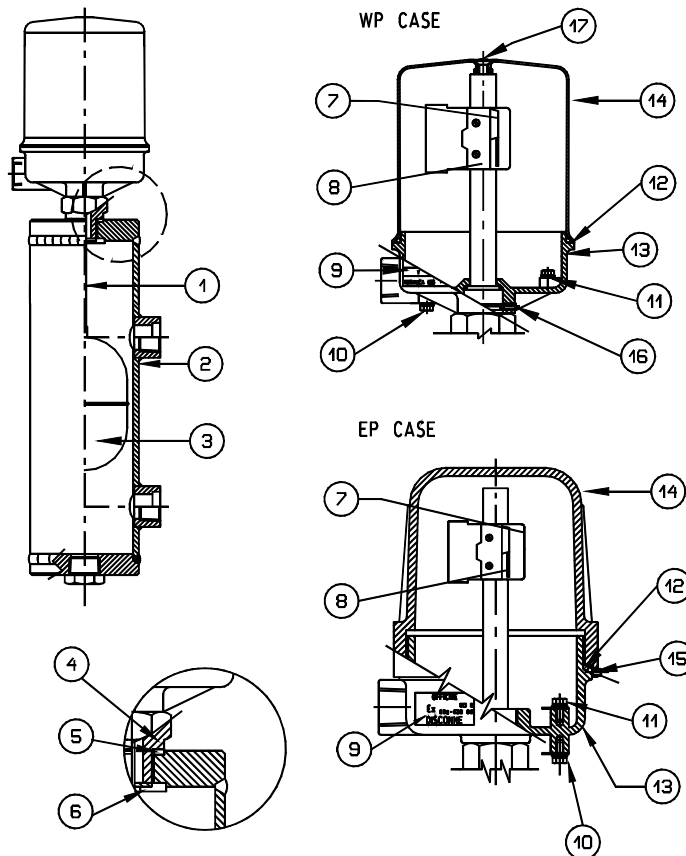

When ordering spare parts, always indicate the instrument's serial number.

You can find it on the ratings plate on the case (see Pos. 9) and has 5 digits preceded by the letter "F" (e.g.: F45678).

11. TROUBLE-SHOOTING

Series 60 level switches are not normally subject to malfunctions.

If the level switch fails to trip, check the float and the micro-switch as explained at paragraph 7 MAINTENANCE.

12. DISPOSAL

Once the level switches have reached the end of their working life, they should be sent for disposal in accordance with prevailing regulations.

During their disposal, pay special attention to the polymers, resins and rubber used in their construction (PVC, PTFE, PP, PVDF, neoprene, viton etc.).

Metal components may be recycled after removing the gaskets, special coverings as requested by the customer or other plastic materials.

WARNING:

If mercury bulb micro-switches (code VD) have been installed, they must be disposed of in accordance with prevailing regulations concerning toxic substances; the other types of micro-switch are not subjected to these regulations.



13. WARRANTY

All series 60 level switches are guaranteed against manufacturer defects for a period of 12 months from the date of shipment.

In the event of a malfunction, if the defective part is returned within the above-mentioned warranty period, Officine Orobiche undertakes to replace any damaged parts under warranty (excluding transport costs), provided that the defect is not the result of the improper use of the instrument.

Officine Orobiche may not be held liable for any improper use of its products where these are used for ends other than those indicated in the specifications forming part of the order.

No claims for damages will be accepted in the case of improper use.

Damages and/or expenses, whether direct or indirect, arising from improper installation or use of the instrument shall not be attributable or debited to Officine Orobiche under any circumstance.

The instrument may be used for a maximum period of 10 years from the date of delivery.

After said period, the customer has two alternatives:

- 1) Replace the instrument with a new one.
- 2) Have the instrument overhauled by Officine Orobiche

HOW TO RETURN INSTRUMENTS

Any returned instruments must be accompanied by a sheet indicating:

- 1) The name of the customer
- 2) A description of the material
- 3) Details of the fault
- 4) Process data
- 5) Liquids with which the instrument has come into contact

The returned instrument must be perfectly clean, free of dust and deposits; otherwise, Officine Orobiche may reserve the right to refuse to carry out the required maintenance and return the item "as found" to the customer.

FINAL NOTES

Every instrument is supplied fully assembled with all the accessories requested by the customer.

Only in exceptional cases will the various components be supplied separately.

We therefore recommend that the customer inspects the delivery on arrival and immediately notifies Officine Orobiche of any discrepancies.

N.B. IN CASES WHEN THE INSTRUMENTS ARE MEANT TO BE USED IN AREAS FEATURING POTENTIALLY EXPLOSIVE ATMOSPHERES, THE USER SHALL COMPLY WITH THE ADDITIONAL SAFETY INSTRUCTIONS ATTACHED TO THE STANDARD ONES.