

INSTRUCTION MANUAL FOR LEVEL INDICATORS TLT SERIES

1. INSTRUMENT DESCRIPTION

Level transmitters for fluids, of the TLT series are used for measuring with remote re-transmission in a 4/20 mA current two wires.

The fluid shall not be adhesive or highly viscous and shall not feature solid particle in suspension. The standard version is fit for a maximum density of 0.6 Kg/dm³ and pressure up to a maximum value of 50 bar.

The temperature of use shall range within -45°C and +85°C. Versions featuring different density, pressure and temperature values are manufactured on demand.

The instrument can also be supplied for interface service (measurement between two fluids which cannot be mixed together).

It is mounted on top of the vessel through a Flanged or Threaded connection.

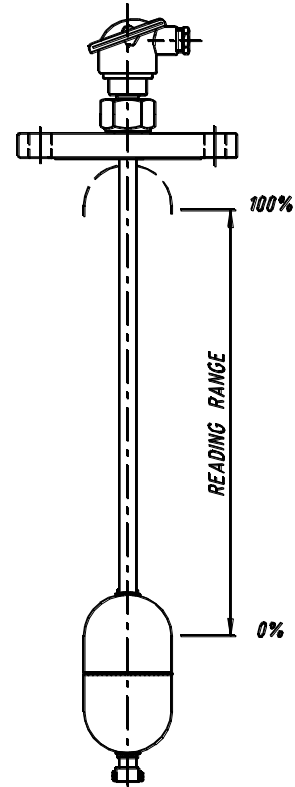

2. MODEL IDENTIFICATION

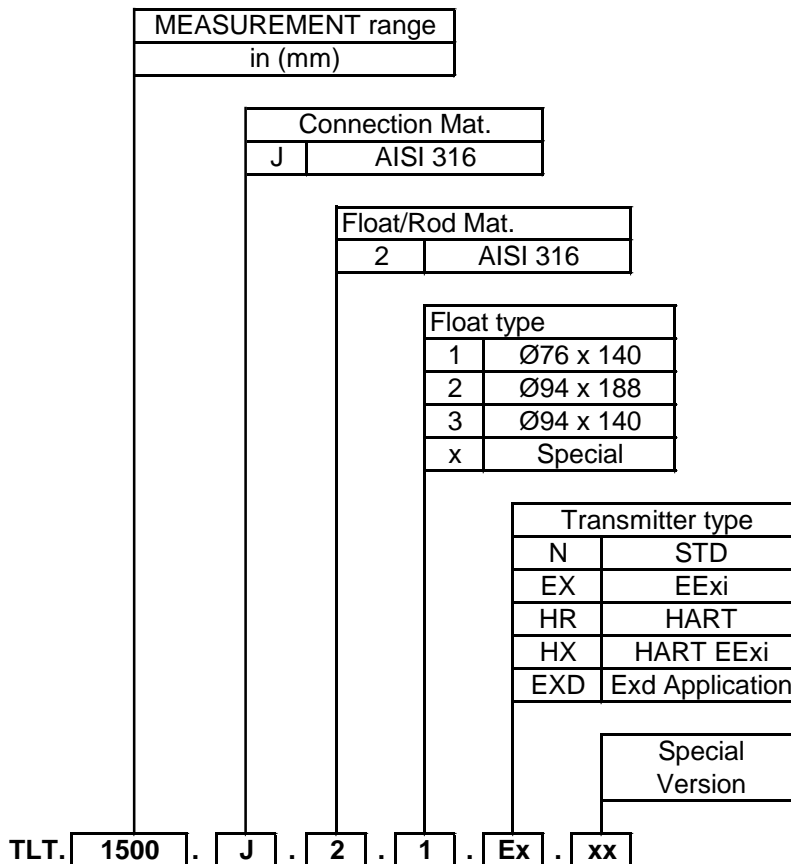

3. OPERATING PRINCIPLE

Operation is based on the hydrostatic principle (Archimedes Law).

The float (1) containing a permanent magnet (5) runs along a rod (2), inside which a potentiometer chain (3) made up of reed contacts and resistances is found.

The magnetic field of the float closes in a sequence the various reed bulbs so as to create a resistance variation that is proportional to the position of the float itself.

A converter (4), located in the instrument's head transforms the resistance variation into a 4/20 mA current variation.

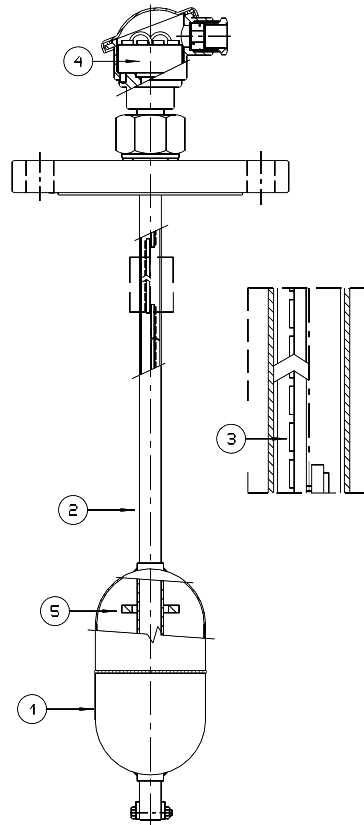

4. INSTALLATION

4.1 MOUNTING

Before performing the installation, ensure the vessel connection and the instrument connection are compatible and check that the use is compatible with the ratings printed on the nameplate (pressure, temperature, density, etc.)

The instrument shall not be used with a fluid that tends to adhere or crystallize, since this would block the float that runs along the guide rod.

The level indicator of the TLT series shall be installed in an upright position. (Maximum angle= 10°).

If the instrument connection point is less than the float diameter, remove it and mount it from the inside of the vessel (in compliance with the "TOP" position located on the float).

The type "A" mounting is typical for transmitters of reduced length and for calm fluids whereas type "B", is preferential for long lengths and agitated fluids (the rod is fixed on the bottom).

Bumps or flexures of the rod can cause the potentiometric chain, to be handled with the utmost care, to break.

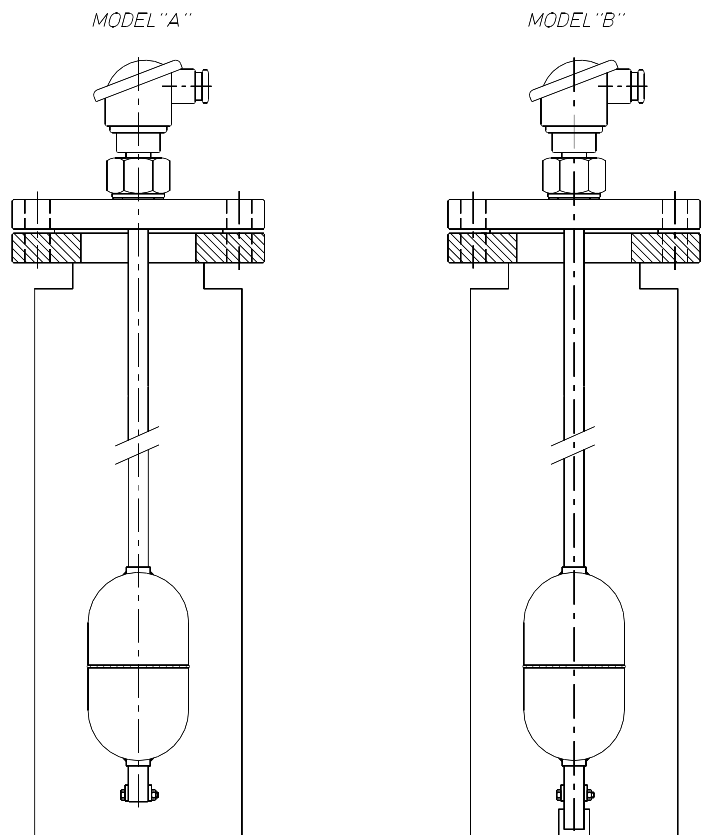

The diagram provided here shows an example of installation.

The instrument has a “dead” zone both at the beginning (L1) and at the end (L2) of the float run.

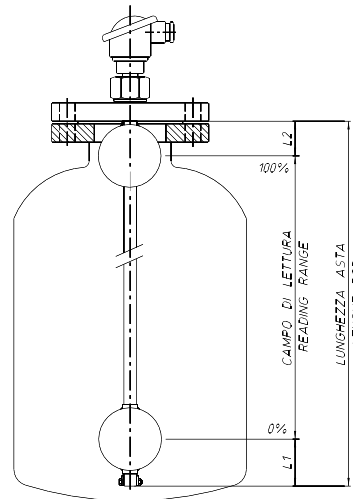

4.2 WIRING

The connection shall be made in accordance with the diagrams provided and the cables shall suit the envisaged application.(temperature, environment, etc.).

The wiring shall be performed in full compliance with the regulations in force in the country of installation.

Shielded cables are preferred to avoid failures due to current peaks.

After the wiring, close the housing and the cable gland tightly.

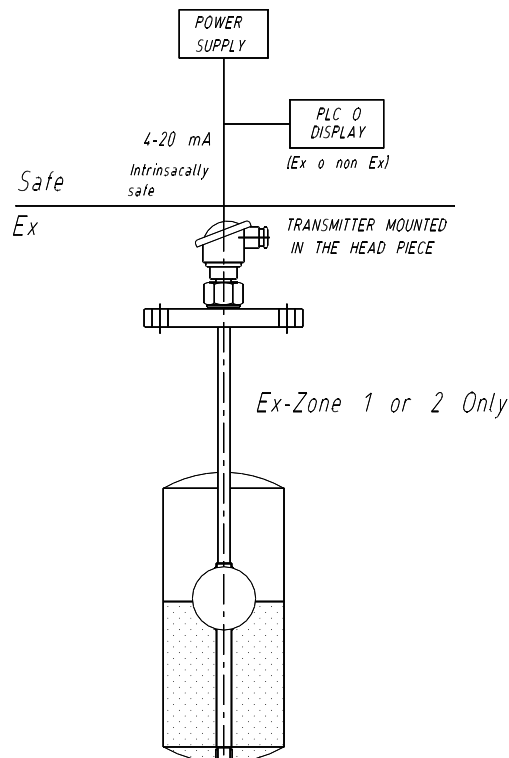
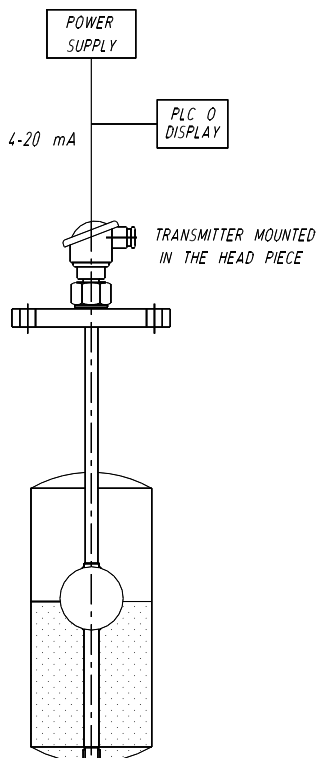
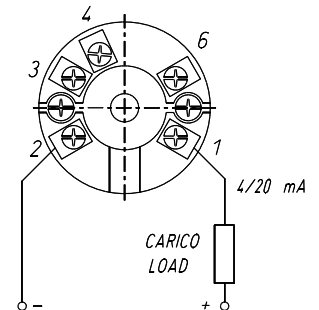

Note for environments featuring explosion risks (Ex)

The level transmitter shall operate through an Exei-certified barrier for zones 1 or 2.

Make sure the TLT transmitter suits the area classification and the characteristics of the flammable substances that are found within the system.

Take all measures required to avoid all sparks, wherever a combustible mixture of gas and air can be found in the environment.

Working within this area is strictly forbidden unless the person at issue is qualified.

Safety measures shall be taken to avoid all risks affecting people and the structure.

5 SETTING AT WORK

Ensure that use does not exceed the allowed limits (e.g. pressure, temperature, and the like) and ensure the instrument correctly performs the measurement, making the level of fluid in the vessel vary a few times.

In cases where this was not possible, the float can be moved by hand. Insert a current meter in serial connection with the line to ensure the transmitter operates properly.

The standard embodiment ranges from 4mA = 0% to 20mA = 100% (on demand, this embodiment can be reversed).

Comply with the feeding voltage, equalling 10-35 Volt for the standard models and 10-28 Volt for the Eexi models.

The maximum load results from the following formula:

$$R_{LOAD} = (V_{SUPPLY} - 8) / 0.023$$

The instrument shall not be operated very close to strong magnetic fields (minimum distance: 1m)

It can only be used with suitable feeders or indicators.

6.SETTINGS

The instrument is factory-set and does not demand any field setting.

The float is set to the required density value.

7.MAINTENANCE

TLT transmitters do not generally require a routine maintenance schedule.

Periodically check, once every six months approximately, that the rod and the float are clean and the instrument operates correctly.

Notes for environments featuring explosion risks (Ex)

Tests and maintenance shall be performed in accordance with the criteria set forth in the related EN standards.

- Terminals and cable connections well tight to avoid overheating.
- Effective grounding system.
- All replaced parts shall be original parts.
- No repair of broken pieces will be allowed.

7.1 NOTICES

- NEVER open the cover without making sure that the voltage supply has been disconnected;
- NEVER leave the housing without the cover for longer than the inspection time;
- NEVER use the instrument with a pressure or a temperature value exceeding the ratings on the nameplate;
- NEVER use the instrument with an electrical rating that exceeds the ratings on the nameplate;
- NEVER make adjustments or replace parts without having carefully read the related instructions; in case of doubts, please contact our Customer Care dpt.;
- NEVER lubricate parts of the instruments;
- In cases when the instrument is used with low or high temperatures, take all measures required to guarantee protection to the service personnel during maintenance.

7.2 FLOAT REPLACEMENT

- Separate the instrument from the vessel and take out the rod with the float;
- Take care not to fold or knock on the rod, since it is very delicate;
- Extract the float by unscrewing the retainer located on the lower end of the rod;
- Insert the new float (take care to keep the TOP position of the float).
- Reassemble the whole set.
- Execute the procedure given in paragraph 5.

8 DIMENSIONAL DRAWING

Dimensional values required:

- C**=Connections
- L**=Field
- D**=Float

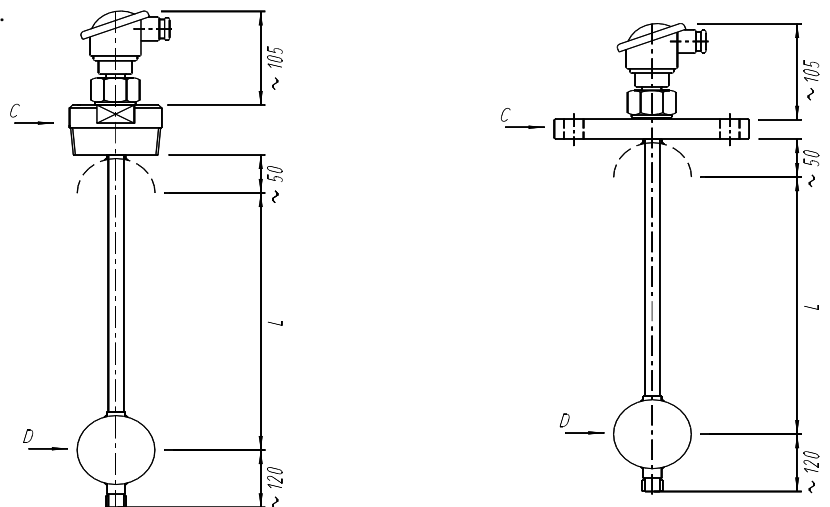

9. SPARE PARTS

The only spare part envisaged is the float.

On ordering spare parts, always indicate the serial number of the unit.

This number is given on the instrument's nameplate that is fixed on it and is a five-digit number preceded by the letter "F" (e.g.: F45678).



10. FAULT FINDING

Level indicators of the TLT series are not generally subject to faults.

IN cases when they do not perform the measurement, perform the test as described in paragraph 7. MAINTENANCE

11. DISPOSAL

Once their service life is over, the instruments need to be scrapped. Please comply with the regulations in force on this subject.

During disposal, special attention must be addressed to polymers, resins and rubbers used in the manufacturing process (PVC, PTFE, PP, PVDF, neoprene, viton, etc.).

Separate mechanics from electronics, the latter having to undergo disposal in compliance with the regulations in force.

All metal parts, once separated from all gaskets, special protective coverings requested by the customer and any other part made from plastics, can be recycled.

12. GUARANTEE

All level indicators are guaranteed as fault-free over a period of 12 months from the delivery date.

In the event of failures, with return of the goods, within the period detailed above, Officine Orobiche will replace all damaged parts in fulfillment of the mentioned guarantee (shipment fees not included), provided that the fault does not ensue from an improper use of the instrument.

OFFICINE OROBICHE shall not be held responsible for any incorrect use of their own products in cases when they are used for purposes other than those detailed on the specifications approved at the order issue stage.

If so, no claim will ever be considered.

All damages and/or expenses, whether direct or indirect, ensuing from an improper use of the unit, shall not be assigned or debited to OFFICINE OROBICHE.

The indicator can be used for a maximum period of 10 years from delivery.

After this period, two new alternatives are possible:

- 1) Replace the unit with a new one
- 2) Have it overhauled by OFFICINE OROBICHE.

INSTRUMENT RETURN PROCEDURE

IN attachment to the unit being returned, please indicate:

- 1) Purchaser's name.
- 2) Material description.
- 3) Fault found
- 4) Process data.
- 5) Fluids used with the unit.

The instrument shall be returned perfectly cleaned and free from dust or deposits, otherwise OFFICINE OROBICHE reserve the right no to perform the required maintenance and return the unit to the sender.

FINAL REMARKS

Each unit is supplied completely mounted and equipped with all accessories required.

Only under special circumstances shall some pieces be supplied separately.

Therefore, we suggest you carefully analyze the supply and immediately notify us of all discrepancies found.

ATTENTION:

IF THE INSTRUMENTS WILL BE USED IN A HAZARDOUS LOCATION THE END USER MUST COMPLY WITH THE ADDITIONAL SECURITY INSTRUCTION ENCLOSED TO THE STANDARD ONES