



ISTRUCTION MANUAL

Magnetostrictive Level Transmitter MD and TLT Series

INDEX

- 1 DESCRIPTION
- 2 SAFETY INSTRUCTIONS
- 3 DESIGN AND FUNCTION
- 4 INSTALLATION
- 5 ELECTRICAL CONNECTION
- 6 ADJUSTMENT
- 7 MAINTENANCE
- 8 DISPOSAL

1. DESCRIPTION

The high-precision MD and TLT series level sensor is designed to provide continuous gauging of liquid media levels in tanks. The measuring principle used by the sensor exploits the physical effect of magnetostriction and is largely unaffected by temperature. This method is particularly ideal where level measurements are required to be extremely accurate, such as in the chemical industry.

The TLT Series is a Reed chain Level Transmitter and it has his own Instruction Manual (see IST/156 “TLT Series Level Indicator”), in this manual is described the magnetostrictive version of this instrument.

The MD Series is designed to be installed as accessory on a 2000 Series Magnetic Level Gauge (see IST/162 “2000 Series Magnetic Level Indicator”).

The MD and TLT Series supplies a 4 ... 20 mA output signal and a digital output signal as HART® protocol.

They are available in three versions:

1. Without display (MG, MX models)
2. With integral display (MG+I, MX+I, MI+I models)
3. With screwed in display



2. SAFETY INSTRUCTIONS

The purpose of the MD/TLT level sensor is to gauge liquid levels in tanks. The level sensor must be used exclusively for this purpose. The manufacturer accepts no liability for any form of damage resulting from improper use.

The level sensor has been developed, manufactured and tested in accordance with the latest good engineering practices and generally accepted safety standards. Nevertheless, hazards may arise from its use. For this reason, the following safety instructions must be observed:

- Do not change or modify the level sensor or add any equipment without the prior consent of the manufacturer.
- The installation, operation and maintenance of the level sensor must be carried out only by expert personnel. Specialized knowledge must be acquired by regular training.
- Operators, installers and service technicians must observe all applicable safety regulations. This also applies to any local safety and accident prevention regulations which are not stated in this manual.

3. DESIGN AND FUNCTION

The design of the MD/TLT level sensor is illustrated in the version with screw-in unit (see following figure).

Inside probe head (1) of the level sensor, concealed by cap (2), are the protected terminal clamps and configuration buttons. The electrical connection is established by an M16 x 1.5 screwed cable gland (3) or M12 plug-in connection at

the top of the probe head and by earth connector (4) at the bottom of the probe head (see chapters “Installation” and “User configuration”).

On the probe tube (5) is a screw-in unit (6) (cutting ring fitting or ferrule fitting) for height adjustment capability or a flange (not shown) for fixed installation. The float (7) is the key component for continuous gauging of the product filling level or interface and is held on the probe tube by a guard ring (8).

The MD Series is supplied without process connection and float.

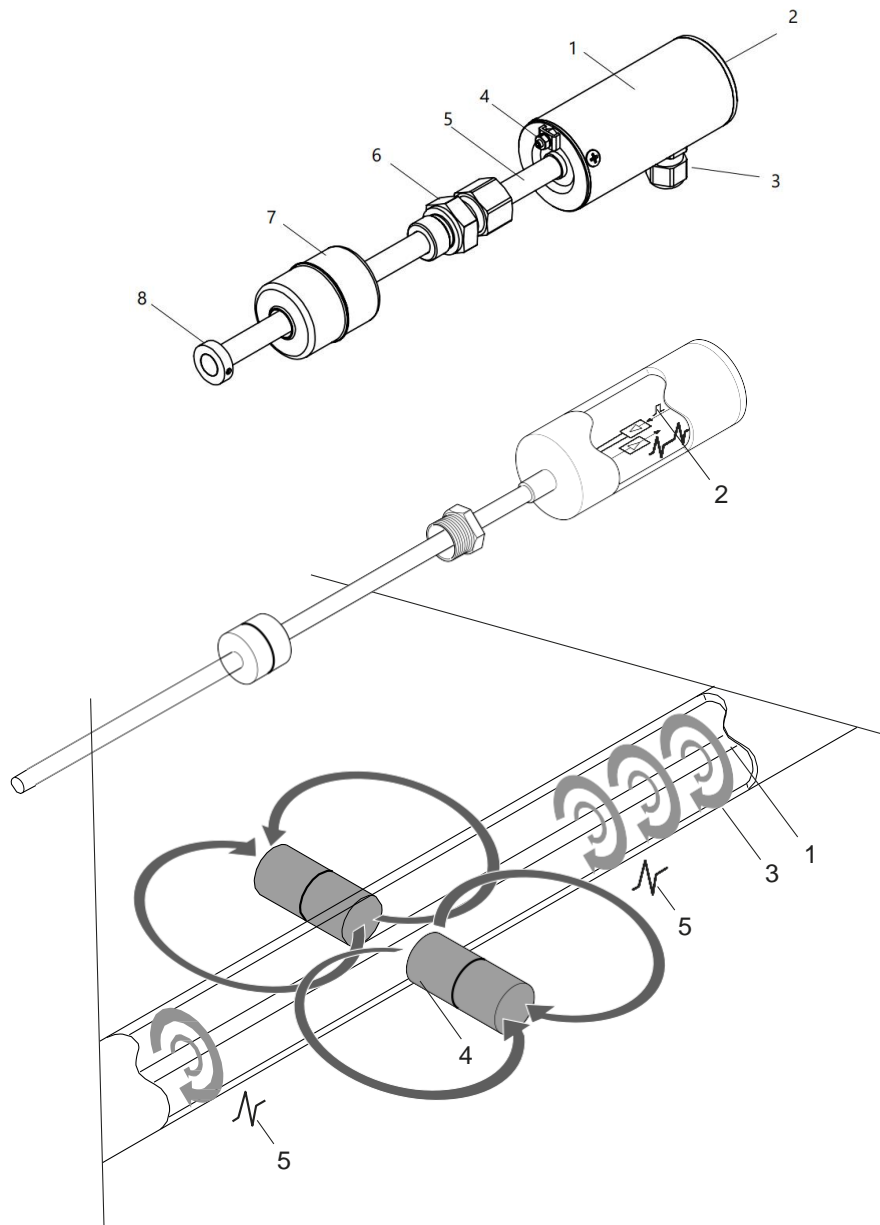

The measuring principle illustrated in the following figure uses the physical effect of magnetostriction and is largely unaffected by temperature. The probe tube contains a tensioned wire (1) made of magnetostrictive material. The sensor electronics transmit current pulses (2) through the wire, which generate a circular magnetic field (3). A magnet (4) inside the float acts as the filling level sensor. Its magnetic field applies an axial magnetic field to the wire. The superposition of the two magnetic fields produces a torsional wave (5) at the float position, which then propagates along the wire in both directions. One wave propagates directly to the probe head, the other propagates down to the bottom of the probe tube and is reflected. The time between the current pulse being transmitted and the wave arriving at the probe head is measured. From these propagation times, it is possible to determine the current position of the float.

4. INSTALLATION

WARNING:

- When installing and maintaining the level sensor in potentially explosive areas, the national rules must be observed (Explosion Protection Regulations, Industrial Health and Safety Regulations, Equipment Safety Regulations and the specific conditions of the EC-Type Examination Certificates). The generally accepted rules of engineering and these operating instructions must be observed.
- All applicable local safety and accident prevention regulations not included in this manual must also be observed.

This section describes how to install the level sensor depending on the type (see the following figure).

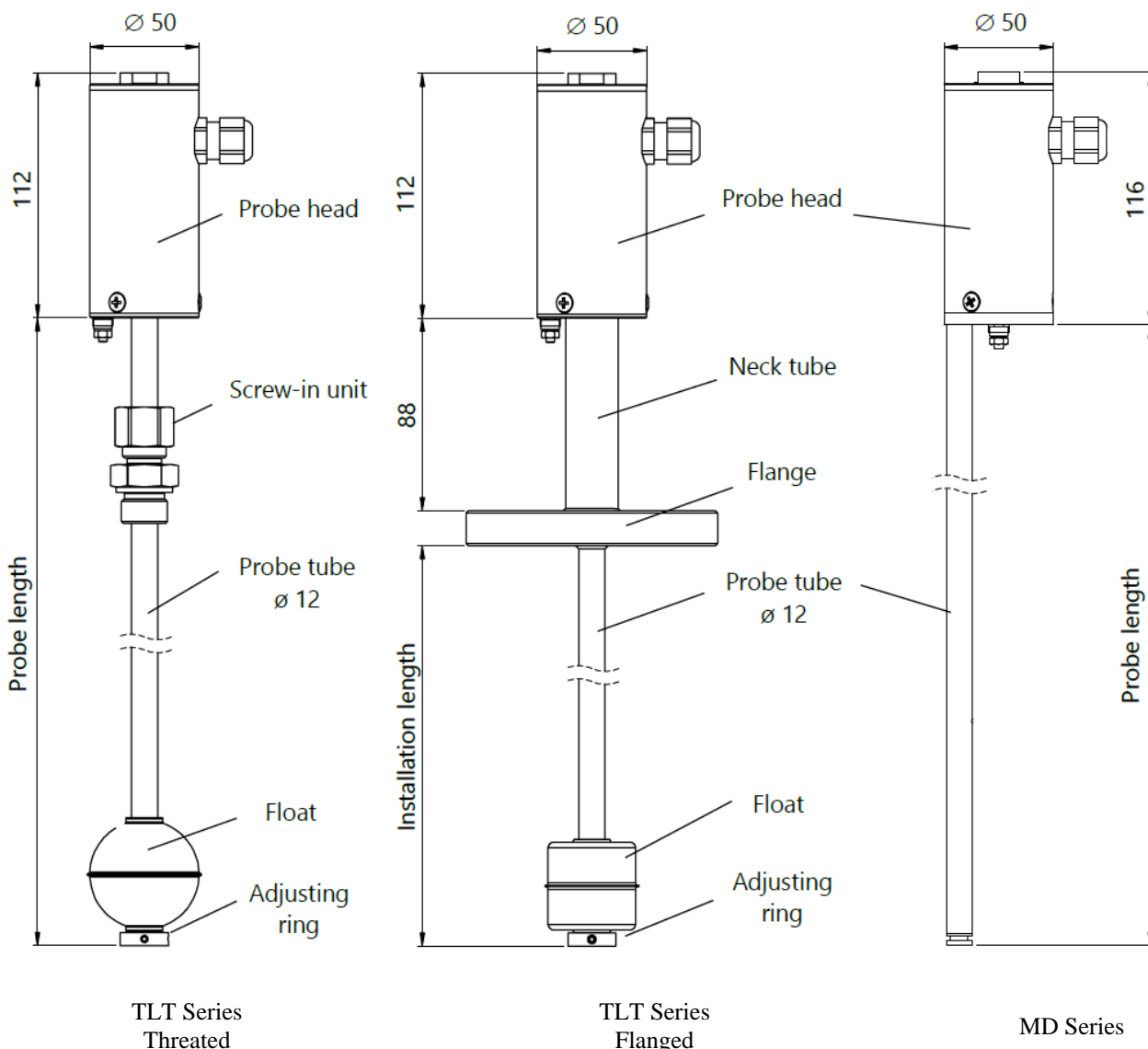

WARNING:

- During installation, take great care not to bend the probe tube, and protect the float from shock and impact loads.
- Installing a level sensor in areas exposed to a powerful external magnetic field is not permitted because this could impair gauging.
- The level sensor can also be fitted into the tank from underneath. If the container additionally is pressurized, then the maximum length of the level sensor is 2 m.

- If the float is removed during installation, it must be slid back onto the probe tube afterwards with the “TOP” marking oriented towards the probe head to enable correct measurements.

4.1 Installation TLT Series Threaded

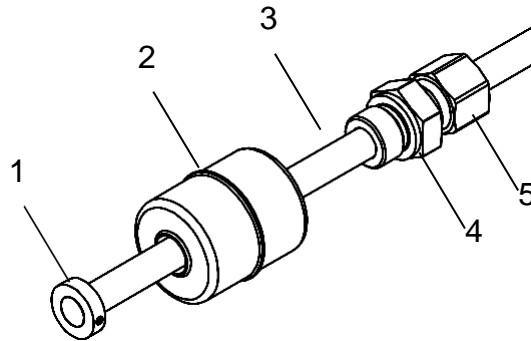

Removal of the float is necessary only if the float does not fit through the installation opening in the tank. Otherwise, please proceed directly to steps 3, 6 and, if applicable, 7.

Insert the level sensor into the tank (see Figure 4):

1. Loosen both set screws, remove guard ring (1) and float (2) from probe tube (3).
2. If necessary, slot screw-in unit (4) onto the probe tube.
3. Insert the level sensor into the tank, provide screw-in thread (4) with a suitable sealing material, screw it in and tighten.
4. Slide float (2) back onto probe tube (3). For correct gauging, the float must be slid onto the probe tube with the “TOP” marking oriented towards the probe head.
5. Refit guard ring (1) on the tube, align the set screws with the groove and tighten.
6. Adjust the height of the process connection and fix the union nut (5) by hand finger-tight.
7. Fix the union nut (5) with a wrench by a 1/4 clockwise turn (see following figure).

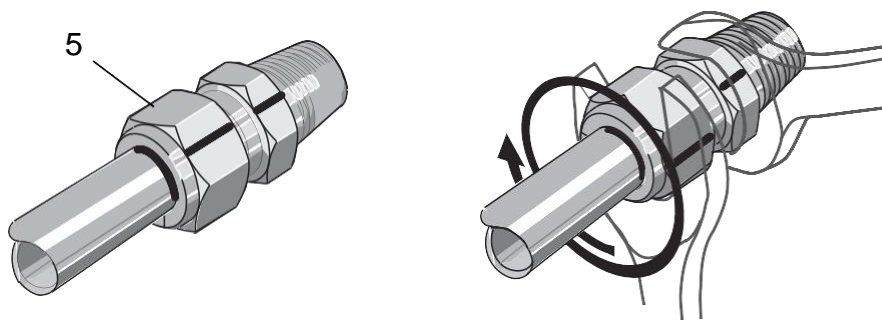

4.2 Installation TLT Series Flanged

The probe tube is permanently welded to the flange, which means that the installation length cannot be altered. Fasten flange and seal with the flange bolts and nuts. The screws or nuts and the seals are the responsibility of the operator and must be chosen depending on the fluid. The fasteners and seals must comply with the requirements of the standards EN 1092-1, EN 1514 and EN 1515.

If the float does not fit through the installation opening, see installation instructions chapter 4.1.

4.3 Installation MD Series

The level sensor is mounted at the side of the 2000 Series tube using suitable non-magnetic fasteners.

- To ensure reliable gauging, the probe tube must be fitted with no deformation on the outside.
- The distance between the probe and bypass tubes must be as small as possible.
- Only OFFICINE OROBICHE magnetic level indicators can be used.

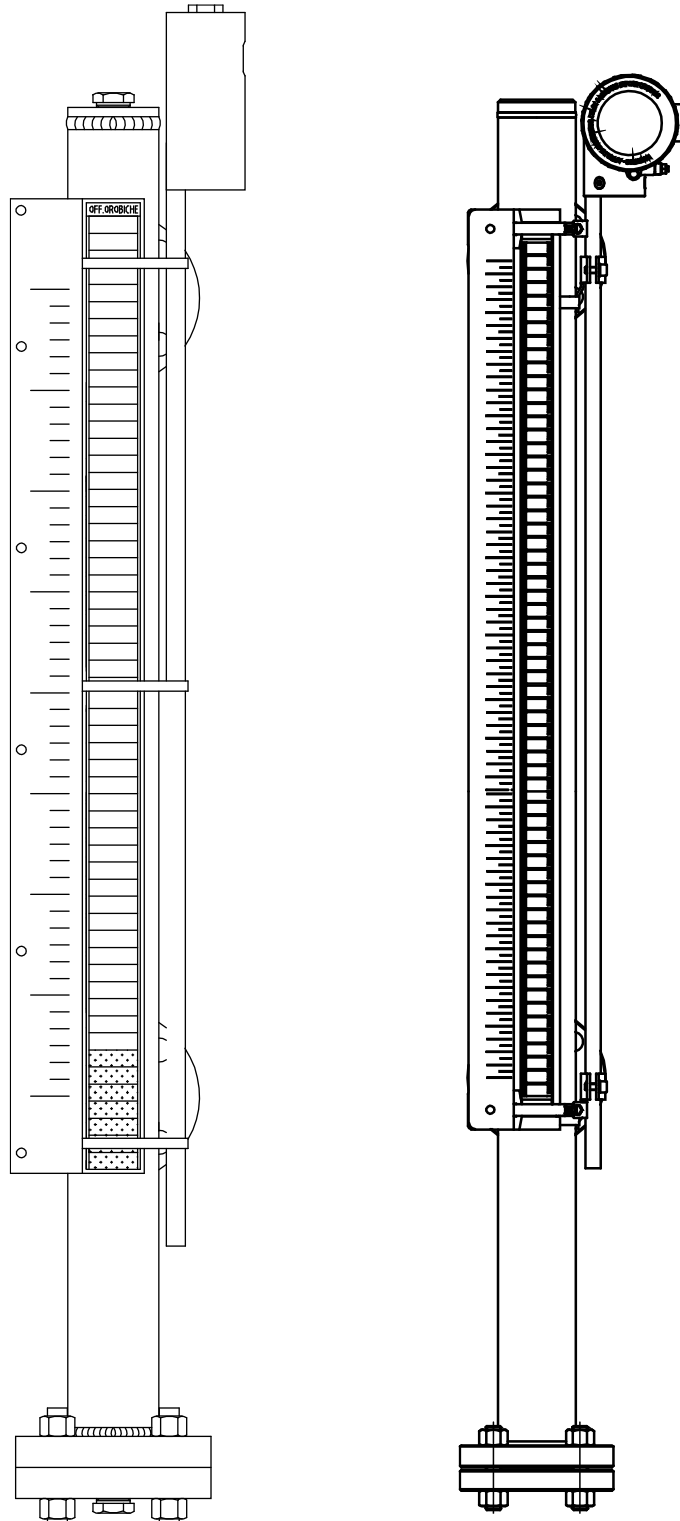

5. ELECTRICAL CONNECTION

5.1 Wiring Diagram for Safety Area Version

The level sensor without Ex approval is installed in accordance with the following wiring diagram:

Without display model

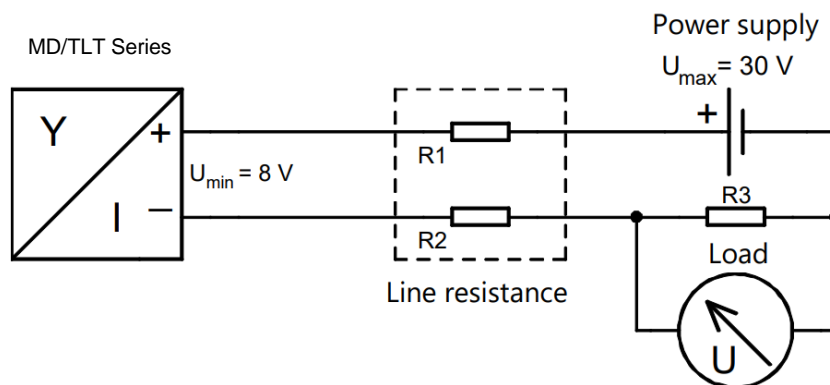

Power supply: $U_{\max} = 30 \text{ V DC}$

Minimum supply voltage: $U_{\min} = 8 \text{ V}$

Permissible total resistance (including cable resistance and load): $\Sigma R = (U - U_{\min}) / 0.0215 \text{ A}$

Display model

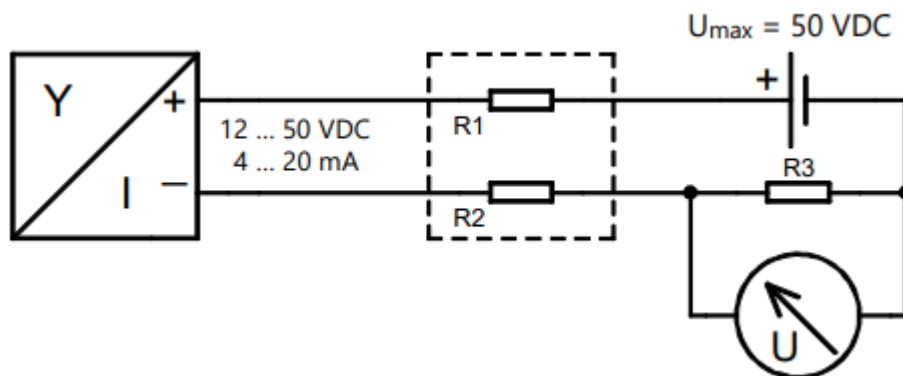

Power supply: $U_{\max} = 50 \text{ V DC}$

Minimum supply voltage: $U_{\min} = 12 \text{ V DC}$

Maximum current consumption $I_{\max} = 21.5 \text{ mA}$

For connection of the cable, see chapter 5.4

5.2 Wiring Diagram for Ex i Version

The level sensor with Ex approval is installed in accordance with the following wiring diagram:

Without display model

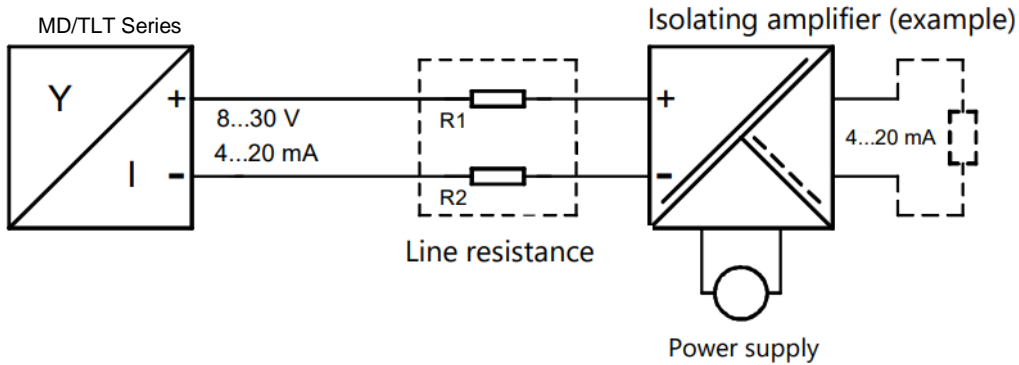

Power supply: $U_{max} = 30 \text{ V DC}$
 Minimum supply voltage: $U_{min} = 8 \text{ V}$
 Permissible total resistance (including cable resistance and load): $\Sigma R = (U - U_{min}) / 0.0215 \text{ A}$

Display model

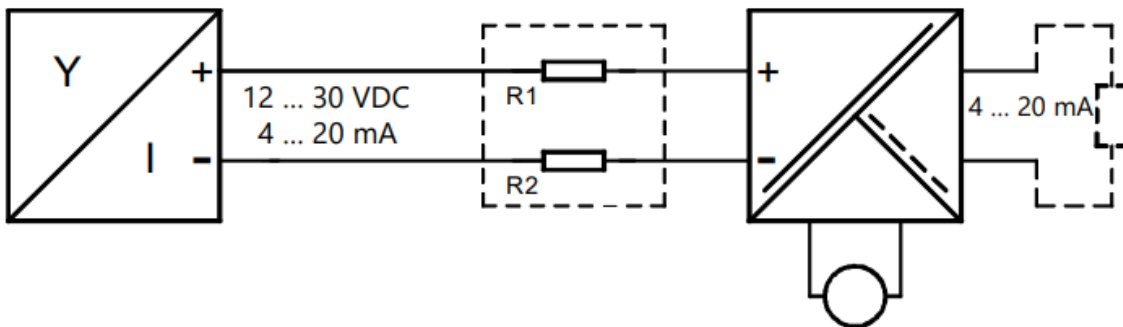

Power supply: $U_{max} = 30 \text{ V DC}$
 Minimum supply voltage: $U_{min} = 12 \text{ V}$
 Maximum current consumption $I_{max} = 21.5 \text{ mA}$

5.3 Wiring Diagram for Ex d Version

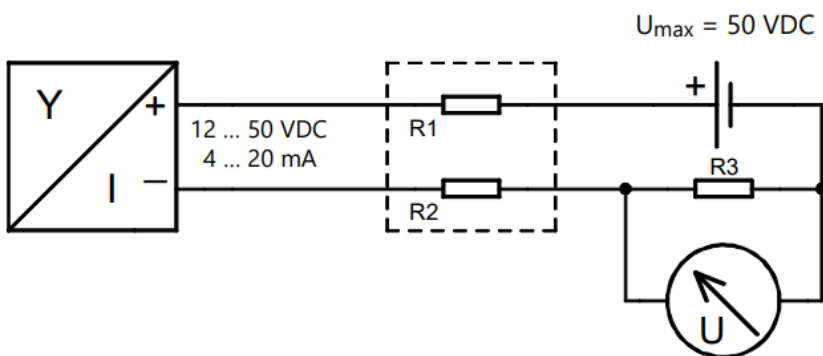

Power supply: $U_{max} = 50 \text{ V DC}$
 Minimum supply voltage: $U_{min} = 12 \text{ V}$
 Maximum current consumption $I_{max} = 21.5 \text{ mA}$

The intrinsically safe version of the level sensor, when installed in a potentially explosive atmosphere, is permitted to be connected only to isolating amplifiers that have been certified by a recognized inspection authority and offer electrical outputs that meet the conditions mentioned in the certificate. Further data can be found in the certified area certificate certificate.

If the level sensor is to be used in a potentially explosive atmosphere, always make sure that the permissible external capacitance (C₀) and inductance (L₀) of the isolating amplifier are not exceeded (refer to the electrical data in the certificate).

Used in an explosion-proof application, the connecting cable to the isolating amplifier must be marked, preferably as a blue cable for intrinsically safe electric circuits.

For connection of the cable, see chapter 5.4.

5.3 Cable Length

The maximum cable length depends on the total resistance (see chap. 5.1 / 5.2), composed of the line resistances and the load of connected devices.

- The cable (length and cross-section) must be chosen so that the supply voltage will not fall below the sensor-specific minimum voltage (8 V) in the event of a maximum current consumption (21.5 mA).
- If the level sensor is to be used in a potentially explosive atmosphere, always make sure that the permissible external capacitance (C₀) and inductance (L₀) of the associated equipment are not exceeded (refer to the electrical data in the EC-Type Examination Certificate).
- Because of the voltage drop of 12 V the connection housing HPH Ex d and the safety barrier SB1 can be used only at a supply voltage higher than 20 volts.

The following table shows the maximum total resistances at different supply voltages, and cable resistances at various cross-sections:

Supply voltage [V]	Max. total resistance [Ω]	Cable cross-section [mm ²]	Cable resistance per m copper cable [Ω/m]	For connection housing HPH Ex d suitable (yes/no)
12 (-5%)	158	0.5	0.0356	no
		1.0	0.0178	no
		1.5	0.0119	no
24 (-5%)	688	0.5	0.0356	yes
		1.0	0.0178	yes
		1.5	0.0119	yes

The max. cable length is calculated as follows:

$$L = (((U - U_{\min}) / I_{\max}) - R_B) / R_Q$$

L = Cable length [m]

U = Supply voltage [V] (with negative tolerance value -5%)

U_{min} = Minimum supply voltage [V] = 8 V

I_{max} = Maximum power consumption [A] = 0,0215 A

R_B = Load

R_Q = Cable resistance per m copper cable [Ω/m] at cable cross-section Q [mm²]

EXAMPLE:

Supply voltage 12 V (± 5%)

Supply voltage U = 11.4 V (12 V - 5%)

Minimum supply voltage U_{min} = 8 V

Maximum power consumption I_{max} = 0.0215 A

Load R_B = 86,8 Ω

Cable resistance per m copper cable R_Q = 0.0356 Ω/m with cable cross-section Q = 0.5 mm²

$$L = (((11,4 - 8) / 0,0215) - 86,8) / 0,0356 = 2000 \text{ m}$$

Thus a cable with forward and return line (2-wire) can be up to 1000 m long.

5.4 Wiring

The level sensors may only be wired with the power disconnected.

5.4.1 Without display version

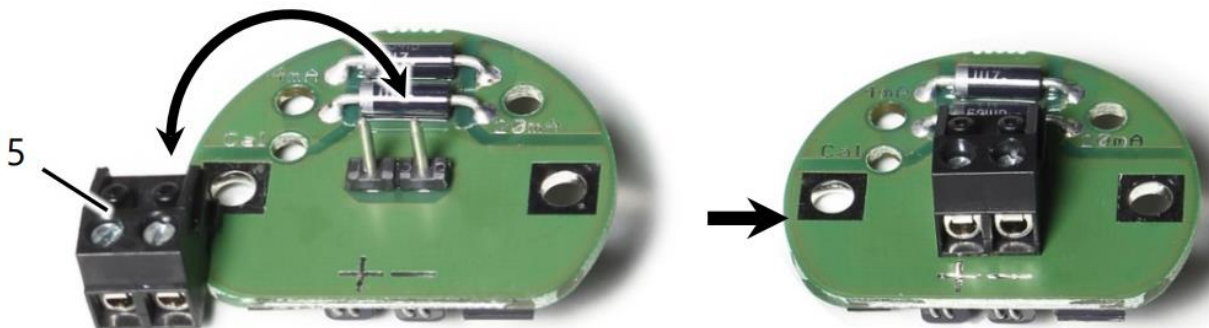
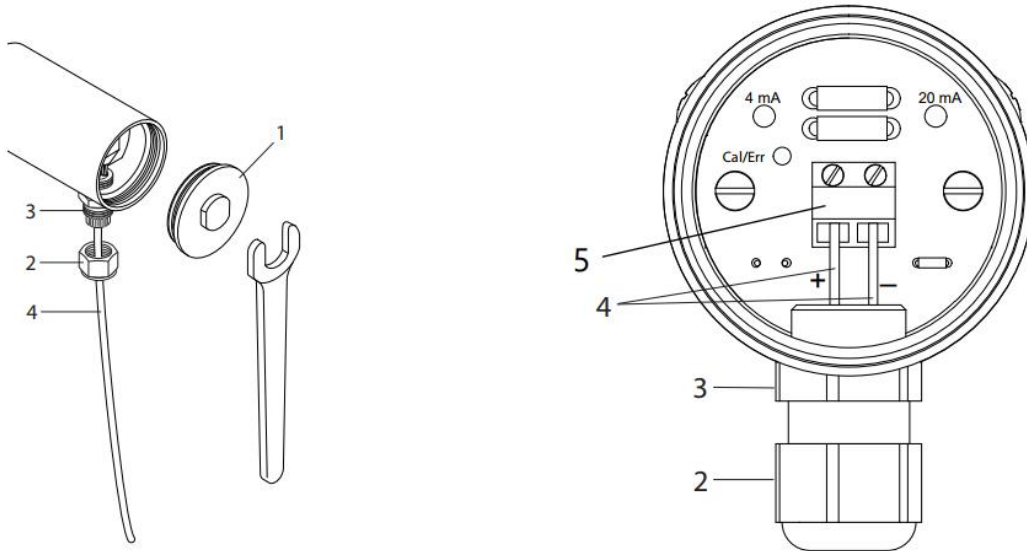

The wiring must be carried out only with the power disconnected.

For the wiring of the level sensor, proceed as follows:

1. Unscrew probe head cover (1) using an open-ended spanner.
2. Loosen union nut (2) of screwed cable gland (3).
3. Feed the two-core cable (4) into the union nut (2) and tighten the nut. The outside diameter must be 5 to 10 mm.
4. Remove screw terminal (5).
5. Connect the two-core cable (4) to the (+) and (-) marked poles of the screw terminal (5).
6. Plug the screw terminal (5) back on. The cable must have no traction!
7. If necessary, set reference points (see chapter 6.1).
8. Screw probe head cover (1) back on.

The earth connector on the underside of the probe head can be used for earthing or equipotential bonding.

Protect the probe head against the ingress of water. An external cable diameter of 5 to 10 mm ensures reliable sealing of the cable entry. Make sure that the cable gland is screwed tight, and close the probe head cap firmly.

5.4.2 Display version

The terminal compartment is accessible after removing the rear screw cover from the probe head. To do this, screw the locking screw of the cover into the housing with a 3 mm Hex key.

After the wiring has been completed, the cover must be screwed on again and secured against unintentional loosening.

The electrical connection is made using the push-in PCB terminal clamps.

Fine-wire conductors with wire-end ferrules and single-wire conductors can be plugged in directly. The terminal clamps can be unlocked with a screwdriver to insert or remove the conductors. The blade width should be 3.5 x 0.5 mm.

The permissible cable cross-section for single-wire conductors is in the range of 0.5 to 2.5 mm² (20 to 12 AWG). A cable cross-section in the range of 0.5 to 1.5 mm² is permissible for fine-wire conductors with wire-end ferrules.

For the wiring, continue as follows

1. Insert the connection cable through the lateral opening into the terminal compartment
2. Connect the connection cable to the right PCB terminal clamps

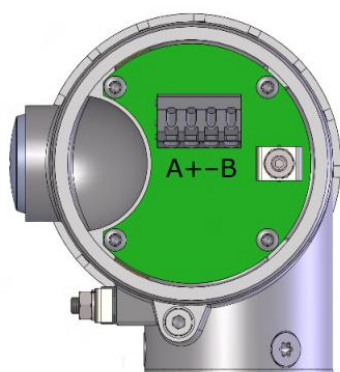

The connection cable between the (intrinsically safe) TORRIX (Ex) XTS and the associated equipment must have the following properties:

- 2-wire unshielded cable
- For Ex ia applications the colour blue or marked blue (cable for intrinsically safe power circuits)

SIGNAL	CONNECTION
Used internally	A
Sensor voltage	+
Sensor voltage	-
Used internally	B

5.4.3 Display version with heater

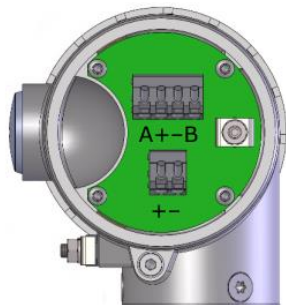

The High-Temperature version (-55 °C to +85 °C) is additionally equipped with a heater for the display. The supply voltage for the heater is connected to the 2-pin PCB terminal clamp.

The earthing or equipotential bonding must be carried out by the installer in accordance with the national installation regulations applicable in each case. The earth connector of the probe head can be used for earthing or equipotential bonding requirements.

Note also the general installation regulations.

A certified Ex d or Ex t cable gland (depending on the application) must be used in classified areas.

6. ADJUSTMENT

6.1 Without display version

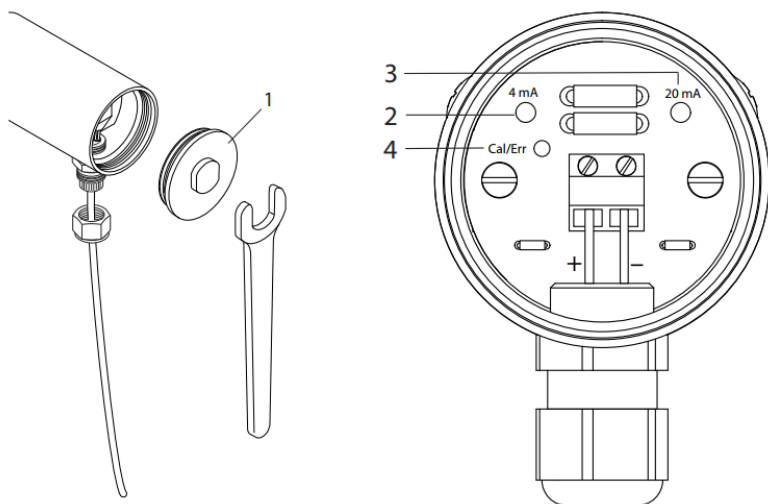

Versions that support the HART® protocol enable the adjustment described below to be carried out remotely without the probe head having to be opened.

6.1.1 Measuring span at the level sensor

To enable configuration of the 4 mA and 20 mA points at the MD/TLT level sensor, two buttons and an LED (light emitting diode) are provided near the terminals inside the probe head.

By default, the level sensor is set to maximum measuring span with 4 mA at the sensor base and 20 mA at the probe head. The measuring span is configurable for adaptation to the tank concerned. However, a minimum clearance of 10 mm must be observed.

If this minimum clearance is not observed, the display direction of the level sensor will be reversed automatically (ullage measurement).

Through configuration, it is also possible to have the measured value output inverted: e.g. the level sensor can be set to maximum measuring span with 4 mA at the probe head and 20 mA at the sensor base.

1. Unscrew probe head cap (1) using an open-ended spanner.
2. Press and hold 4 mA button (2) or 20 mA button (3) for at least 3 seconds. The green LED begins to flash.
3. The level sensor is now in configuration mode. The current consumption of the level sensor is 12 mA. If no button is pressed again, the level sensor remains in configuration mode for 20 seconds before reverting to measuring mode and discarding any changes. In configuration mode, the 4 mA or 20 mA reference point, or both, can be modified in any order.
4. To define a reference point move the float to the desired reference point and
 - briefly press (0.1 to 2 seconds) “4 mA” button (2) to define a current consumption of 4 mA at this position
 - briefly press (0.1 to 2 seconds) “20 mA” button (3) to define a current consumption of 20 mA at this position.

When the “4 mA” button is pressed, the LED goes out for 5 seconds. When the “20 mA” button is pressed, the LED lights up permanently for 5 seconds.

The sensor then remains in configuration mode for a further 15 seconds before storing the change and reverting to measuring mode.

The new measuring range configuration is not stored until the level sensor reverts automatically from adjustment mode to configuration mode and the LED goes out. The new configuration is retained even if the level sensor is subsequently disconnected from the power supply.

For “dry” settings to be possible in the case of bypass sensors, a magnetic system with spacer bracket will need to be obtained from the manufacturer of the bypass. Configuration can then be carried out even with the sensor removed.

6.1.2 Current consumption in failure mode

If a malfunction is preventing the level sensor from recording a plausible float position, i.e. the measured level is incorrect, the sensor will enter the failure mode after a short time. Failure mode signaling conforms to the NAMUR NE43 recommendation. The failure current is set by default to 21.5 mA but this value can also be set to 3.6 mA.

To configure the current consumption in failure mode (see Figure 11).

1. Unscrew probe head cap (1) using an open-ended spanner.
2. Press and hold both the “4 mA” (2) and “20 mA” (3) simultaneously for at least 3 seconds. Green LED (4) “Cal/Err” flashes rapidly. The current consumption of the level sensor is 16 mA. After 5 seconds, the LED stops flashing and indicates the selected failure current consumption for 2.5 seconds. If the LED is on permanently, I_{failure} is 21,5 mA, if the LED turns off, I_{failure} is 3,6 mA. If no button is pressed again, the level sensor remains in failure mode for a further 2.5 seconds before reverting to measuring mode and discarding any changes.
3. To set a current consumption
 - of 3.6 mA during the dwell time (10 sec) in the fault mode, briefly press the “4 mA” (2) button (0.1 ... 2 seconds).
 - of 21.5 mA during the dwell time (10 sec) in the fault mode, briefly press the “20 mA” (3) button (0.1 ... 2 seconds).

The new measuring range configuration is not stored until the level sensor reverts automatically from adjustment mode to configuration mode and the LED goes out. The new configuration is retained even if the level sensor is subsequently disconnected from the power supply.

4. Screw probe head cap (1) back on.

If, during operation, the level sensor detects that the level cannot be output correctly due to an insufficient supply voltage, it enters failure mode and sets current consumption to 3.6 mA (regardless of any failure current settings).

6.2 Display version

6.2.1 Display rotation

If the display needs to be rotated, the housing cover with the viewing window must first be removed. To do this, screw the locking screw of the cover into the housing with a 3 mm Hex key. When the cover is removed, the display and adjustment module can be rotated in a range of almost 360°. Additional detents every 90° make adjustment easier. After alignment, screw the housing cover back on and secure with the locking screw.

6.2.2 Values showed



The following information is shown in the measured value display:

- TAG
- Measured value, up to three simultaneously
- Bar graph

The values that can be showed are

- Level in percentage (default option) [Percent]
- Level in mm, inch or other units [DV0 – LEV1]
- 4-20 mA value [Current]
- Temperature [DV2 – TEMP]

How to change the TAG:

OK button > Configuration > Display > TAG

Enter the measuring point designation (8 characters). OK to move to the next character.

Arrow keys to select the character. To exit the menu press ESC when the cursor is on the first character.

How to change the value:

OK button > Configuration > Display > Values > Value 1

How to change the unit of measure:

OK button > Configuration > Measurement > Units

- Level (mm, cm, m, in, ft)
- Temperature (°C, °F)

How to change the Offset:

OK button > Configuration > Measurement > Offset

How to change the Damping:

OK button > Configuration > Measurement > Damping

How to change the Alarm current:



OK button > Configuration > Output > Alarm current

6.2.3 Errors

The following error messages can be displayed:

- Signature error
- Parameter error
- HART parameter error
- Probe internal error
- Probe error communication
- Supply voltage too low

6.2.4 Icons meaning

	FAULT	The error display is shown. An error prevents normal function.
	CONFIGURATION	The configuration is shown. Changes can be made according to the menu Structure.
	SIMULATION	The simulation that can be activated via the Diagnosis ► Simulation menu is running. The current on the 4 ... 20 mA interface is simulated and therefore does not follow the process value.

6.2.5 Calibration

OK button > Configuration > Output > 4 or 20 mA point

Move the float to the desired point.

Take over value > OK button

7. MAINTENANCE

Before returning any equipment, please contact Officine Orobiche.

Any returned instruments must be accompanied by the Officine Orobiche returning module.

The returned instrument must be perfectly clean, free of dust and deposits; otherwise, Officine Orobiche may reserve the right to refuse to carry out the required maintenance and return the item “as found” to the customer.

8. DISPOSAL

Once the level transmitters have reached the end of their working life, they should be sent for disposal in accordance with prevailing regulations.

During their disposal, pay special attention to the polymers, resins and rubber used in their construction (PVC, PTFE, PP, PVDF, neoprene, viton etc.).

Metal components may be recycled after removing the gaskets, special coverings as requested by the customer or other plastic materials.