



## INSTRUCTIONS FOR USE AND MAINTENANCE FLOWMETER SERIES TMN-250 ; TMG-250

### 1. INSTRUMENT DESCRIPTION

All metal flowmeter without seals for installation on vertical piping with rising flow.

Suitable for use with high pressure and high temperature and various types of fluids (corrosive, viscose fluids, etc.).

Can be fitted with remote transmission of measurements, two wires (4/20 mA) and alarm contacts for minimum and/or maximum flow rate.

Model TMN-250 is suitable for liquids, while model TMG-250 can also be used for gases.

The TMG-250 can also be fitted with a self-regulating flow rate device at either the inlet or the outlet of the flowmeter.

### 2. MODEL IDENTIFICATION

The instrument is identified by means of the model code. This code is marked on each instrument together with the process data.

To get to know the coding in full detail, please read the catalogue report, which is also provided here below.

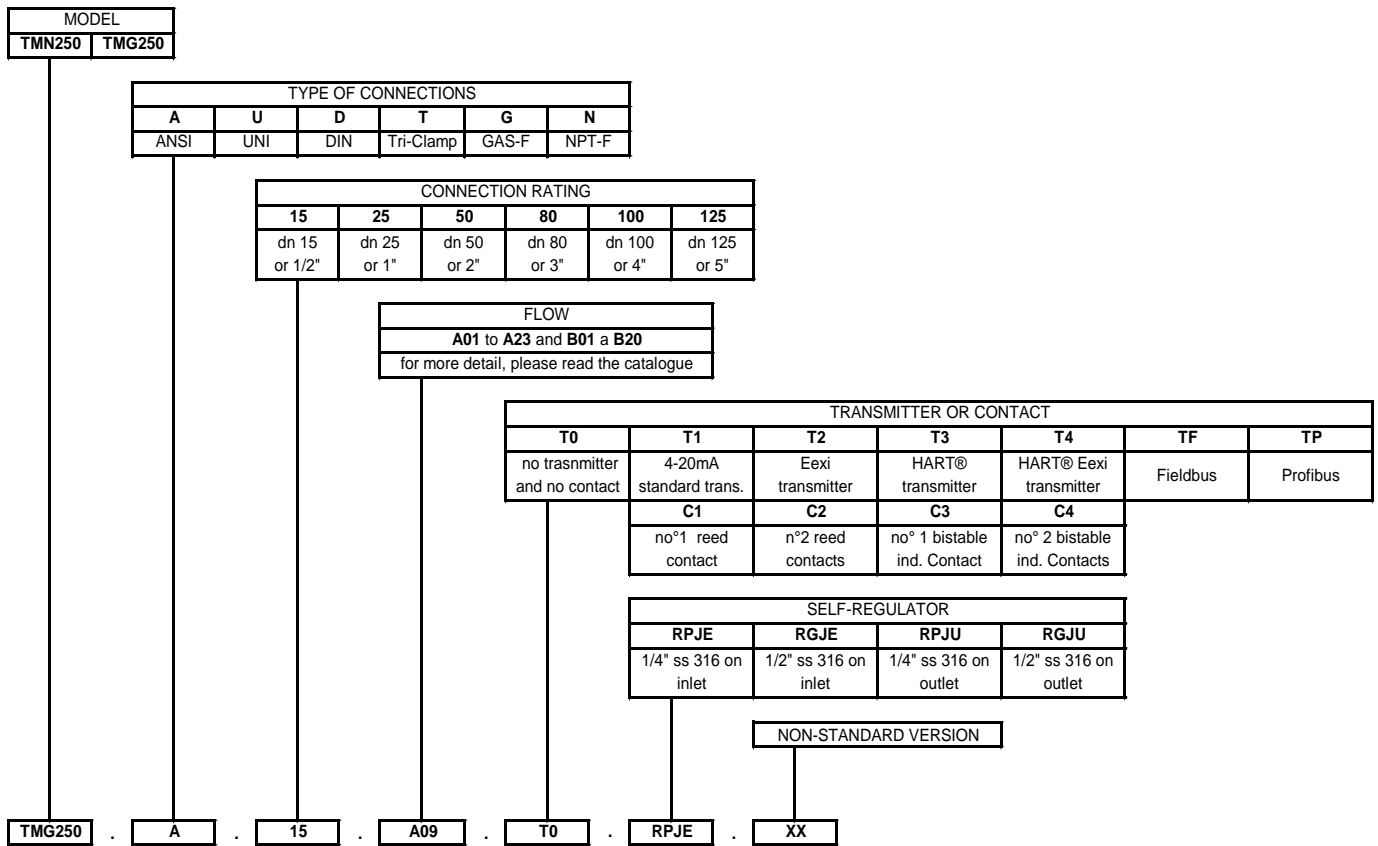

Instruments can be equipped with various accessories, such as:

- Throttle valves
- PTFE contact parts
- High temperature
- High pressure
- Steam jacket
- AISI 316 housing
- Eexd-certified housing
- Amplifier for sensor inside the housing

### 3. OPERATING PRINCIPLE

The flowmeter consists of a measuring tube with a free float inside, fitted with a magnet.

There is an indicator unit outside this tube, in a casing, consisting of a mobile element with a finger and magnet that is moved by the float within through magnetic force and so lets one read the flow rate.

Model TMN-250 has a tapered float that runs inside a calibrated diaphragm, while the TMG-250 has a measuring taper and a float with a calibrated corner that runs inside this.

model TMN-250

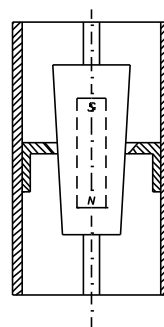

model TMG-250

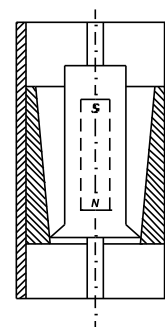

### 4. INSTALLATION

#### 4.1 INSTALLATION IN THE PLANT

Before installing the flowmeter, make sure that:

- The instrument and level switch connections are compatible.
- The connections are perfectly aligned and parallel to the piping.
- The flow is rising.
- The use of the instrument complies with the ratings data punched on the plate (pressure, temperature, flow rate, etc.).

Avoid applying mechanical stress on the indicator unit casing.

**Open the housing and remove the pointer retainer located inside, as shown in the picture beside.**

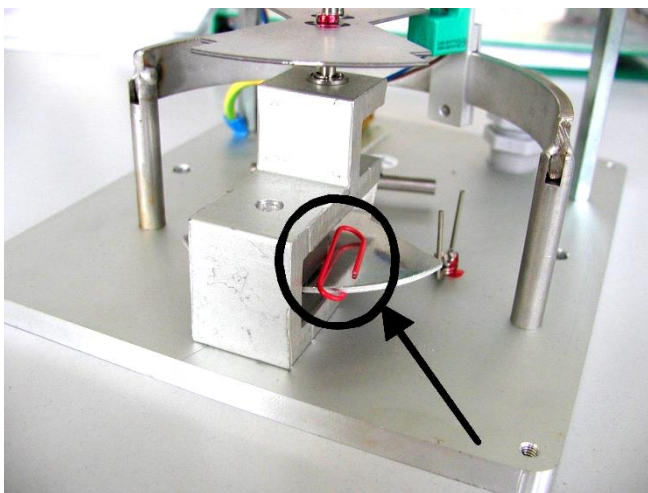

#### 4.2 WIRING

- Before wiring, please ensure the electric rating of the installed sensor is correct;
- The instrument is equipped with a terminal board located within the housing;
- Inject voltage to the sensor and perform the setting of the tripping point.

##### 4.2.1 NAMUR SENSOR

- Connect the sensor feeding cables according to the diagram, and mind polarities;
- For instruments used in areas featuring explosion hazard, with EExi sensors (type NAMUR), please comply with the instructions of the sensor manufacturer's instructions, provided as annexes to these instructions.

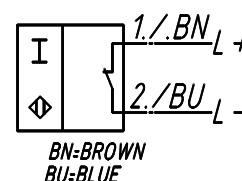

##### 4.2.2 REED SENSOR

The Reed sensor is of the SPDT type, voltage-free, and its rating value is 30 V ac/dc max and 100 mA max.

In cases they are used with inductive or capacitive loads, the contact can be damaged. Hence, the application of suitable protections is required.

For instruments that are used in areas featuring explosion hazards, with Reed-type sensors, no additional measures are required.

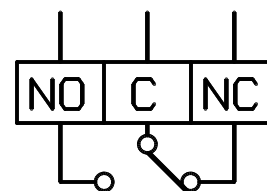

### 4.2.3 4-20mA SENSOR

Connect the sensor's power feeding cables as shown in the diagram beside, and mind polarities.

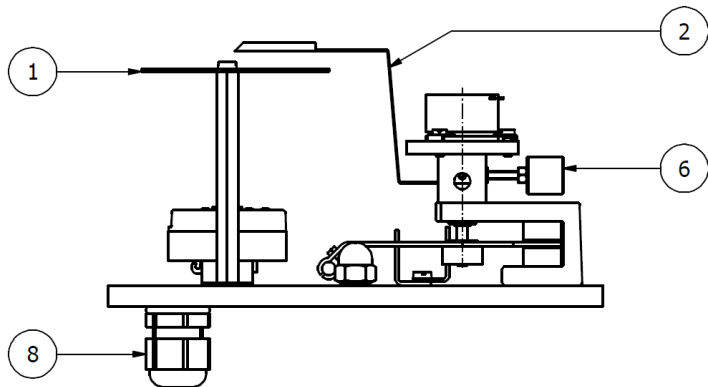
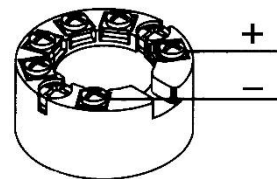

1	Measurement scale
2	Measurement pointer
3	Terminal board
4	Mechanical retainer
5	4-20 mA Sensor
6	Pointer counterweight
7	Base fastening screw

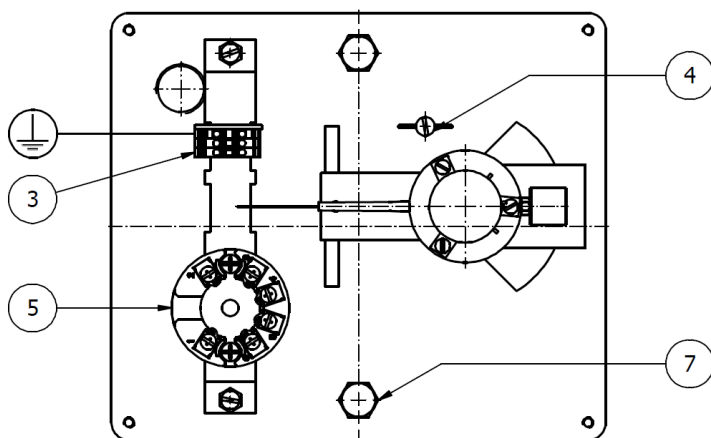

## 5. COMMISSIONING

In the case of a new plant, we recommend adding a magnetic filter at the flowmeter inlet to protect this against possible metal particles in the flow that will be attracted by the float and so provoke wear or even blockage.

If a filter is not fitted, we recommend extracting the float and then washing the piping thoroughly.

We also recommend fitting a by-pass valve as shown in the drawing on the right.

START-UP (all valves closed)

- Slowly open valve (C) to balance the upstream/downstream pressure;
- Slowly open valve (A) until fully open;
- Slowly open valve (B) until fully open;
- Close valve (C) tightly.

If valves (A) or (B) are also used to adjust the flow rate, remember that valve (A) should be used for liquids and valve (B) for gases.

We suggest placing a free pipe that is 5 x DN long upstream and 3 x DN downstream of the flowmeter

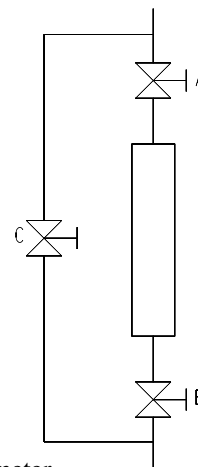

## 6. CALIBRATION

The instrument has been calibrated before leaving the factory and so requires no further calibration on installation.

If alarm contacts are used (optional, unless otherwise specified in the order), these are set at the minimum value (default) and so should be adjusted to the required value during the installation of the instrument.

### 6.1 SETTING THE ALARM CONTACT

To set the alarm contact to the desired value, please comply with the following instructions:

- Open the box;
- Manually move the pointer to the desired alarm flow;
- Loosen the screw (9) and move the pointer until it changes over: as regards falling alarms, the sensor is located in the lower portion of the support, whereas for rising alarms, it is in the upper portion (see the operating range drawing on the following page);
- Lock the sensor;
- **Move the pointer throughout the range** to ensure the sensor works properly;
- Close the box again.

### ARCH VERSION

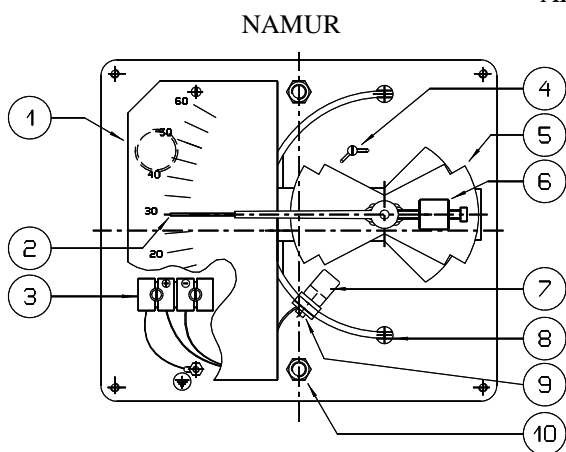

### REED

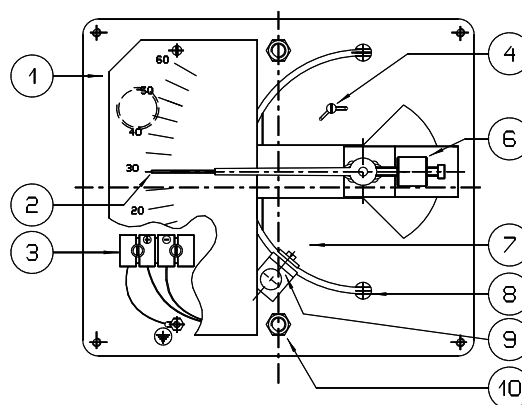

## WITHOUT ARCH VERSION

NAMUR

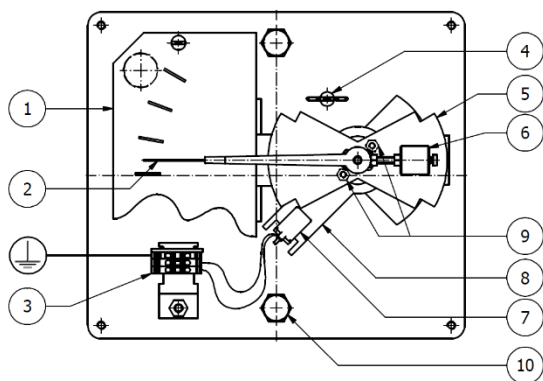

REED

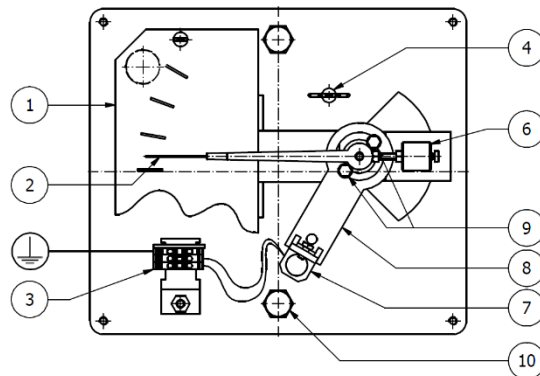

- 1. MEASUREMENT SCALE
- 2. MEASUREMENT POINTER
- 3. TERMINAL BOARD
- 4. MECHANICAL RETAINER
- 5. NAMUR SENSOR CONTROL SECTOR

- 6. POINTER COUNTERWEIGHT
- 7. SENSOR
- 8. SENSOR SUPPORT
- 9. SENSOR SET SCREW
- 10. BASE FASTENING SCREW

## SETTING RANGE

### ARCH VERSION

NAMUR

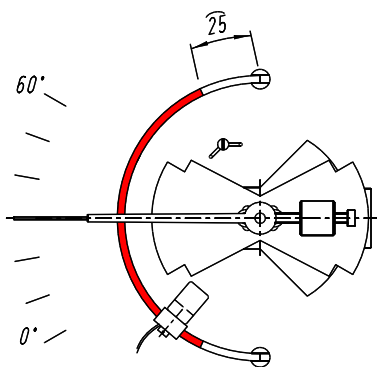

REED

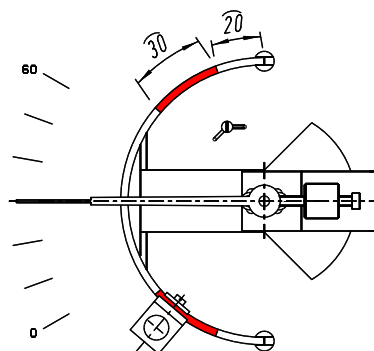

## WITHOUT ARCH VERSION

NAMUR

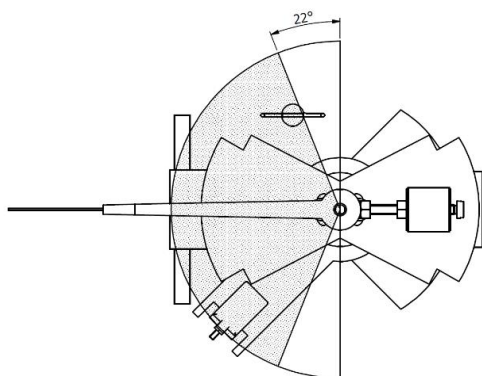

REED

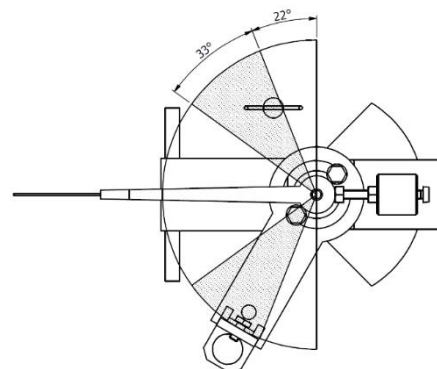



NOTE: TO ALLOW THE INSTRUMENT TO OPERATE PROPERLY, THE SENSOR NEEDS TO BE MANUALLY POSITIONED WITHIN THE RELATED OPERATING RANGE (PLEASE SEE THE COLOURED PORTION OF THE ARCH IN THE ABOVE DRAWING).

## 7. MAINTENANCE

We recommend routing inspection (roughly once every 6 months) to guarantee the efficiency of the instrument.

### 7.1 WARNINGS

- NEVER open the top without first making sure that the voltage has been cut (models with alarms or transmitters).
- NEVER use the instrument with a higher electrical rating than that indicated on the ratings plate (models with alarms or transmitters).
- NEVER leave the cover off the casing containing the indicator unit for more than is strictly necessary for inspection purposes as dust and dirt could damage the bearings of the magnetic indicator.
- NEVER use the instrument at a pressures temperature or flow rate higher than those on the ratings plate.
- NEVER adjust the instrument or replace any parts without having first read the instructions carefully. If in doubt, contact our customer service centre.
- NEVER lubricate the instrument components.
- **NEVER attempt to extract the float from the bottom of the instrument.**
- NEVER use tools when cleaning the instrument that may damage the edges and surfaces inside the instrument body and the float.
- If using the instrument at high temperatures, take all necessary precautions to guarantee the safety of service personnel during maintenance work.

### 7.2 ROUTINE INSPECTION OF THE FLOAT

Make sure that the instrument has been bypassed and that any liquid inside has been drained.

Remove the instrument from the piping.

Extract the float - **ALWAYS AND ONLY FROM THE TOP** - as follows:

- a) Remove the retaining ring (2) that holds the upper stop (3) in place;
- b) Remove the upper stop (3);
- c) Extract the float (1) taking care not to bend the guide rod belonging to the float, otherwise the efficiency of the instrument may be affected. If the rods are visibly bent during extraction, contact our customer service centre. Even the smallest of defects in the rods can provoke errors in measuring or, in extreme cases, the complete blockage of the float;
- d) Clean the diaphragm (4) and the float (1), taking care not to scratch the surfaces or damage the edges. Use a soft brush;
- e) Return the instrument following the above steps in the reverse order. Take special care when re-inserting the float;
- f) Check that the float (1) runs smoothly inside the diaphragm (4). Make the float move from the base towards the top a few times: there should be no friction.

### 7.3 ROUTINE INSPECTION OF THE INDICATOR

Open the casing cover.

Visually check that there is not build-up of dust or dirt. Gently move the finger (8) and check for excessive play or worn details in the magnetic element. If there are damaged parts, replace these immediately: contact our customer service centre for the relevant spare parts.

Follow the steps in paragraph (5) COMMISSIONING above to return the plant to normal operation.

## 8. DRAWINGS OF BODY WITH DIMENSIONS

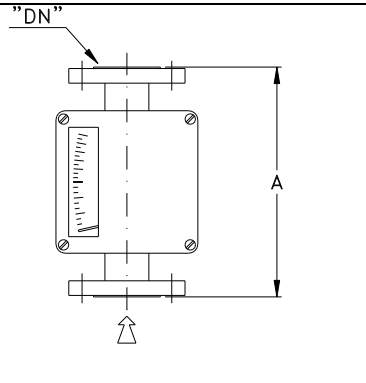
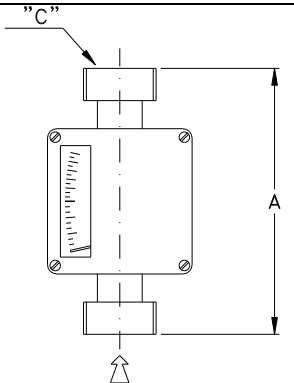
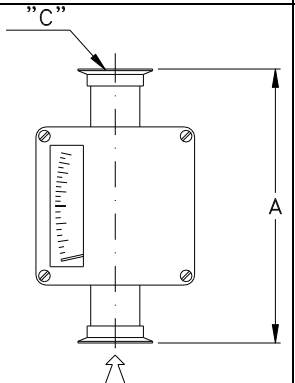
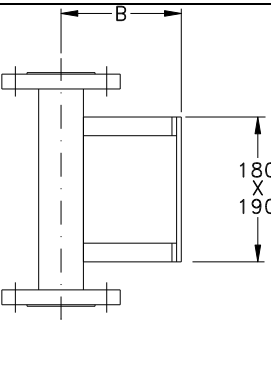
FLANGED		DIN-11851		TRI-CLAMP		SIDE VIEW		
								
DN body	B (mm)	FLANGED		TRI-CLAMP		DIN-11851		
		A (mm)	C	A (mm)	CØ COUPLINGS (mm)	A (mm)	CØ COUPLINGS (mm)	
			ANSI 150	UNI PN16				
15	125	250	½"	DN 15	250	50.4	265	52x1/6
25	130	250	1"	DN 25	250	50.4	265	65x1/6
50	150	250	2"	DN 50	250	90.9	265	95x1/6
80	160	250	3"	DN 80	250	118.9	275	130x1/4
100	180	250	4"(*)	DN 100(*)	---	----	---	----
(*) 5" or ND 125 with heating jacket								
The threaded GAS and NPT couplings have the same ND as the body								

## 9. RECOMMENDED SPARE PARTS (\*)

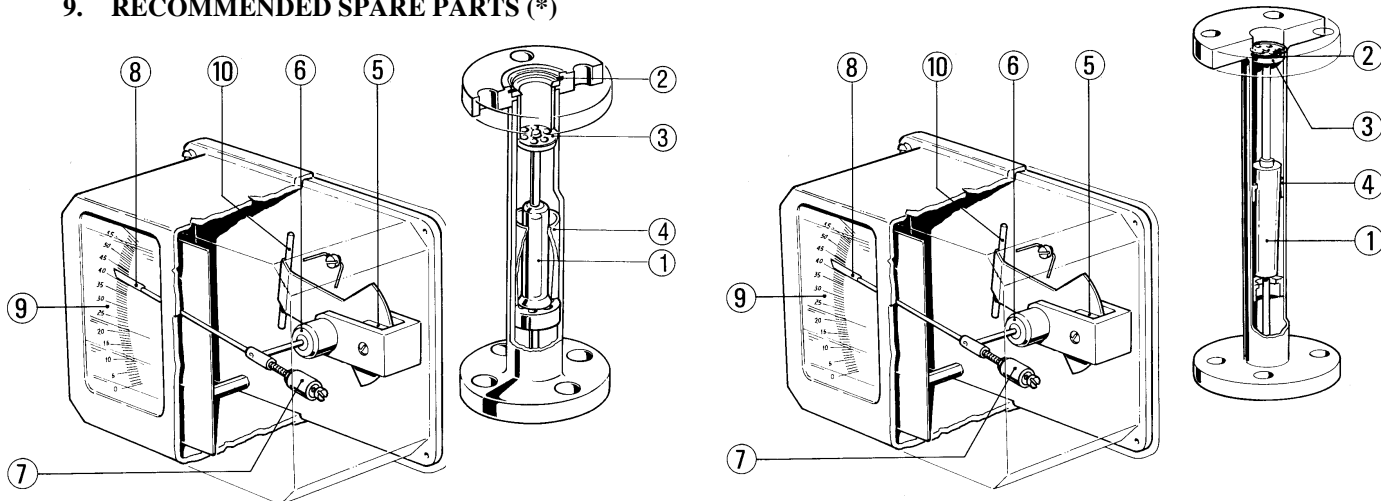

- |       |                |    |                |
|-------|----------------|----|----------------|
| (*) 1 | Float          | 6  | Bearings       |
| (*) 2 | Retaining ring | 7  | Counterweight  |
| (*) 3 | Upper stop     | 8  | Reading finger |
| 4     | Diaphragm      | 9  | Scale          |
| 5     | Magnetic brake | 10 | Magnet         |

**N.B.:** When ordering spare parts, always indicate the instrument serial number.

This can be found on the ratings plate on the body of the instrument, fixed to the casing, and has 5 or more digits preceded by the letter "F" (e.g.: F45678).

If the float or any other part of the flow rate detection system needs to be replaced, this may lead to changes in the precision of measurement. We therefore recommend checking this before using the flow meter again.



## 10. TROUBLE-SHOOTING

TMN-250 and TMG-250 flowmeters are not normally subject to malfunctions.

If a malfunction should occur, check the following:

- Flowmeter fails to measure the flow correctly: check the float and the indicator;
- Liquid leaks from the connection: check the state of the gaskets

All these controls are carried out as explained in paragraph (7) MAINTENANCE above.

Contact our customer service centre if the problem persists or a problem arises that has not been dealt with here.

## 11. SCRAPPING

Once the instruments have reached the end of their working life, they should be sent for scrapping in accordance with prevailing regulations.

When disposing of these, pay special attention to the rubber used in their construction.

Metal components may be recycled after removing the gaskets, special coverings as requested by the customer or other plastic components.

## 12. WARRANTY

All TMN-250 and TNG-250 flowmeters are guaranteed against manufacturer defects for a period of 12 months from the date of shipment.

In the event of a malfunction, if the defective part is returned within the above-mentioned warranty period, OFFICINE OROBICHE undertakes to replace any damaged parts under warranty (excluding transport costs), provided that the defect is not the result of the improper use of the instrument.

OFFICINE OROBICHE may not be held liable for any improper use of its products where these are used for ends other than those indicated in the specifications forming part of the order. No claims for damages will be accepted in the case of improper use.

Damage and/or expenses, whether direct or indirect, arising from improper installation or use of the instrument shall not be attributable or debited to OFFICINE OROBICHE under any circumstance.

The instrument may be used for a maximum period of 10 years from the date of delivery.

After said period, the customer has two alternatives:

- 1) Replace the instrument with a new one.
- 2) Have the instrument overhauled by OFFICINE OROBICHE or an expert technician, who assumes full liability for the future use of the instrument.

## HOW TO RETURN INSTRUMENTS

Any returned instruments must be accompanied by a sheet indicating:

- 1) The name of the customer
- 2) A description of the material
- 3) Details of the fault
- 4) Process data
- 5) Liquids with which the instrument has come into contact

The returned instrument must be perfectly clean, free of dust and deposits; otherwise, OFFICINE OROBICHE may reserve the right to refuse to carry out the required maintenance and return the item "as found" to the customer.

## FINAL NOTES

Every instrument is supplied fully assembled with all the accessories requested by the customer.

Only in exceptional cases will the various components be supplied separately.

We therefore recommend that the customer inspects the delivery on arrival and immediately notifies OFFICINE OROBICHE of any discrepancies.

**N.B. IN CASES WHEN THE INSTRUMENTS ARE MEANT TO BE USED IN AREAS FEATURING POTENTIALLY EXPLOSIVE ATMOSPHERES, THE USER SHALL COMPLY WITH THE ADDITIONAL SAFETY INSTRUCTIONS ATTACHED TO THE STANDARD ONES.**