

INSTRUCTION MANUAL OF SERIES 2000 LEVEL INDICATORS

1. INSTRUMENT DESCRIPTION

Level indicators of the 2000 series are designed to be vertically mounted on the external sides of pressure vessels. Moreover, there is also a 2000T series to be mounted on top of the vessel inside which the float runs.

They are used as fluid level indicators or even for interface service (two fluids with different densities) through the use of WHITE/RED coloured flags.

These models can be equipped with exchange contacts (SPDT) of the REED type for low or high level control and/or alarms, and can be furnished with a probe that allows for the remote transmission of the measured level, through a linear 4/20 mA signal that is proportional to the instrument gauge .

They are used with fluids whose hazardousness makes it unadvisable to use traditional reflection or transparency indicators.

2. MODEL IDENTIFICATION

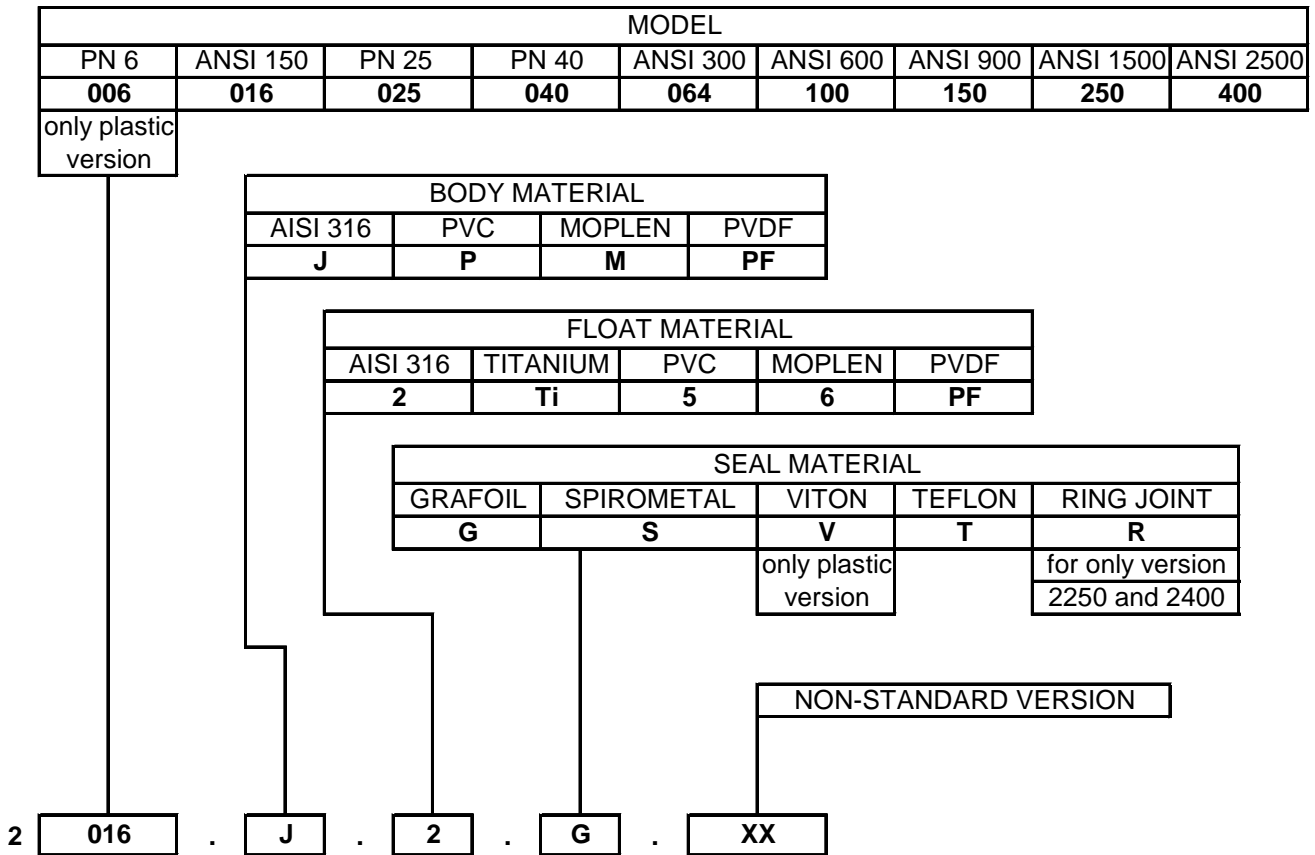

When the instrument is manufactured to be mounted on top of the (leading) vessel, “T” is added to the identification code “ (e.g.: 2016T.J.2.A) .

The instruments can be equipped with various accessories, such as:

- On/off valves
- Draining and/or vent valves
- Centimetric scale located on the raceway side
- Broken float indicator
- Heating or cooling jacket
- Steam marking
- Anti-hoarfrost
- Level sensors
- Level measuring

3. OPERATING PRINCIPLE

Level indicators of the 2000 series base their operation on two physical principles:

- The principle of communicating vessels, where in two vessels that communicate with one another, the fluid level reaches the same height;
- The principle of magnetic attraction between a magnet and a ferromagnetic material, from where the name “Magnetic level indicators” is derived.

The instrument consists of a column made from an “amagnetic” material (1), generally AISI 316 with two trunks that allow for connection with the vessel. Inside the column a float (2) is located, inside which the permanent magnet (3) is lodged.

The float is manufactured in such a way as to allow the magnet to be exactly on the floating line.

ON the outside of the column a raceway (4) is found, whose front side is transparent, inside which a set of flags (5) from ferromagnetic material, featuring a WHITE-coloured side and a RED-coloured one, are located.

Looking at the raceway, the bottom part, where the fluid is in the column, will look RED in colour and the top part, where is the gas stage (or vapour or fluid at a lower density), will look WHITE.

A special feature of level indicators of the 2000 series manufactured by Officine Orobiche is that the magnetic flow radiated by the float has an angle of 360°.

This device guarantees that the instrument operates in an excellent way. Even if the inside float turns, no rotation preventing systems are needed; moreover, the sensors can be safely applied all around the column, which provides simple and safe adjustments.

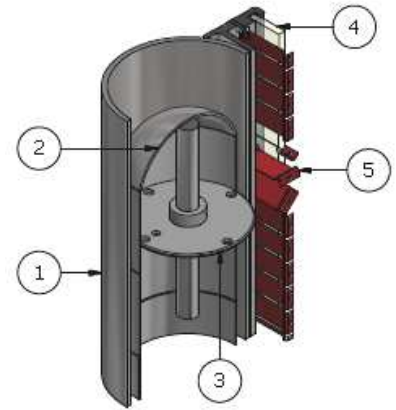

4. INSTALLATION

4.1 ON-SYSTEM INSTALLATION

The instrument shall only be installed and used by skilled personnel.

Before installation, ensure the vessel connections are compatible with those of the instrument.

Under no circumstances can the instrument be burdened with external loads and it is the user’s obligation to protect it from stress; never use it as a fulcrum or an anchorage.

To avoid effects of galvanic corrosion, never use materials featuring a different electrochemical potential. The user shall adopt all the technical expedients that are meant to protect the unit from such a circumstance.

The system shall be equipped with the prescribed safety valve, to remedy all overpressure beyond the specified maximum value.

It is good rule to apply on/off valves to allow the instrument to be easily dismantled, and drain valves to drain all deposits possibly formed within the instrument.

If the formation of air locks or steam is envisaged, please fit vent valves on the upper connections.

WARNING: the instrument shall be mounted vertically and the text “BOTTOM” shall be read on the bottom.

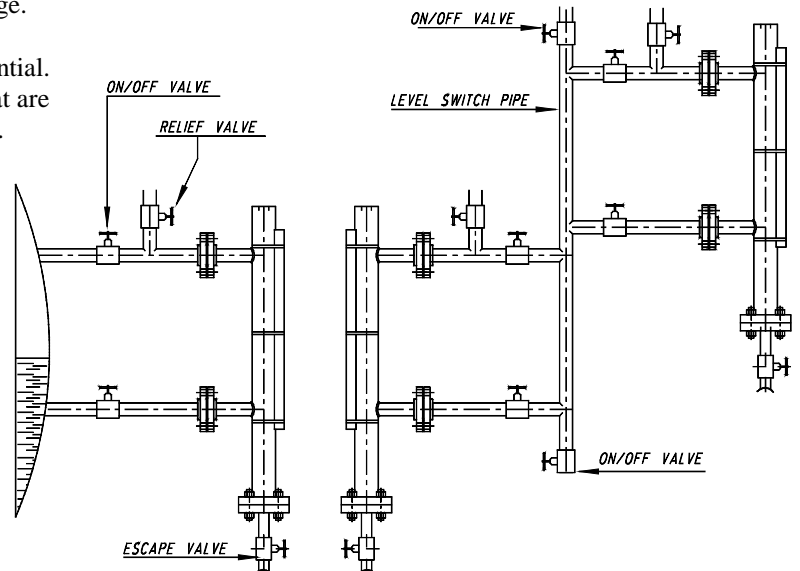

The instrument requires a space below that equals the distance between the visit flange and the connection trunk, in order to allow the float to be pulled out during maintenance.

For installation on vessels that are exposed to strong vibration, please contact our Customer Service department.

The system connection process shall be accurate so that all the elements (flanges, gaskets, tie rods) may find a perfect fit to avoid sealing failures and create useless mechanical stress to the system and/or the instrument.

4.2 ELECTRICAL WIRING

The electrical wiring of sensors or level transmitters shall be carried out in accordance with the prescriptions provided in the special additional instructions that are attached to the unit.

5. SETTING AT WORK

Make sure that the use of the instrument does not exceed the intended use (higher pressure and temperature values, lower specific weight) and that the applied electrical rating (if sensors or transmitters are present) complies with the nameplate data.

Go through these simple and quick steps to ensure the flags turn in a proper manner:

- Position the indicator flags by placing them all on the white and making the magnet slide bottom up on the sensor glass.
- If the flags do not follow the float regularly while setting the system at work, go through the previous action again provided that the magnet is positioned with the opposite polarity as to the previous one.

Special precautions need to be taken when the titanium float is used to prevent it from rubbing against the steel column inside which it slides. This friction between the two materials may produce sparks.

The customer shall make sure that the material that comes into contact with the fluid is compatible with the latter and in full compliance with the fluid ageing properties and the work environment. These instructions can also be found on the order.

6. CALIBRATION

The instrument is factory-set and does not require any calibration to be performed.

The alarm contacts, which are optional unless otherwise stated on the order specifications, are set to the minimum value and shall be set to the required value upon installing the instrument.

4/20 mA level transmitters are calibrated to provide a 4 mA signal with an empty vessel, and a 20 mA one with a full vessel.

7. MAINTENANCE

We suggest carrying out a periodic routine servicing (once every 6 months approximately) to ascertain the correct service state of the instrument.

7.1 WARNINGS

- NEVER use the instrument at a temperature or a pressure that exceeds the values specified on the rating plate;
- NEVER perform settings or replace parts without having read the instructions beforehand; in case of doubts, please contact our customer service department;
- NEVER lubricate any part of the instrument;
- NEVER use any instrument cleaning tools that are likely to damage the edges and surfaces inside the instrument body and the float;
- When the instrument is used at high temperature values, always take all of the precautionary measures required to safeguard the working staff during the maintenance work stages.
- If the instrument is used with very high temperatures, take all precautionary measures required to guarantee personal protection to the personnel on duty during the various maintenance stages.
- For instruments exceeding 6 metres in length, it is greatly recommended to provide a further instrument clamping point

7.2 ROUTINE CHECKS OF THE FLOAT

Ensure that the instrument is disconnected from the system and with no fluid left inside.

- Open the instrument by loosening the bolts and pull out the float by removing the lower flange of the body.
- Inspect the body column and make sure that all incrustations and/or deposits have been removed (if necessary, carefully clean them away);

8. DIMENSIONAL DRAWINGS OF THE BODY

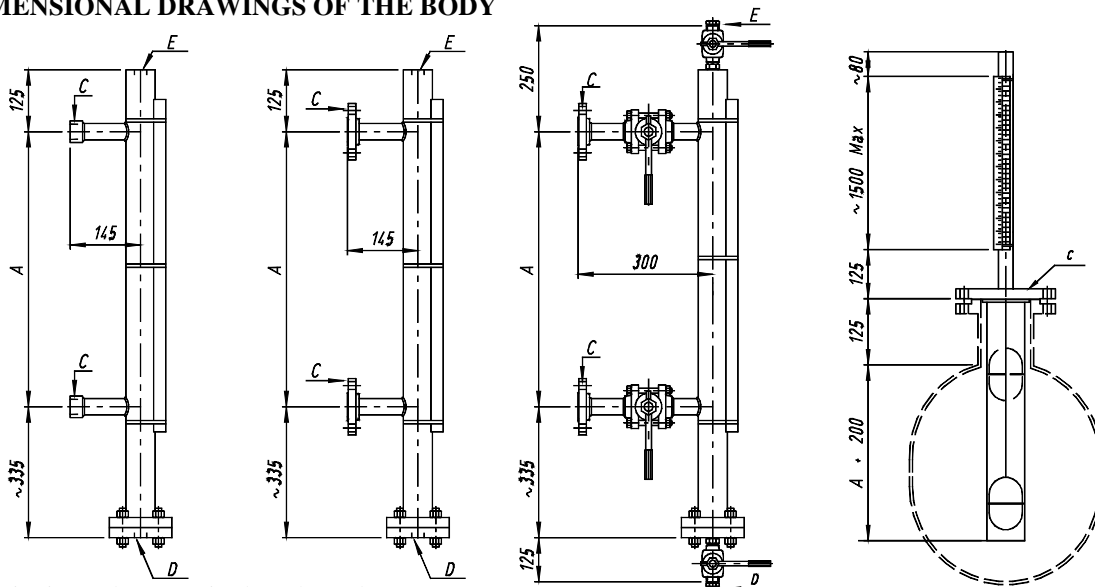

Dimensioning values required on the order
A = range **C** = connections **D** = draining **E** = vent

VERSION WITH JACKET OR TRACING

As a function of the process fluids, it might be necessary to heat or cool the level indicator column; there are two versions that meet this requirement.

In **Fig. A**, the instrument is provided with a stainless steel jacket that is welded onto the column; the space between the jacket and the column is run by a heating or cooling fluid.

On the other hand, in **Fig. B** the instrument is equipped with 4 stainless steel tubes that come into direct contact with the column. A heating or cooling fluid flows inside them, too.

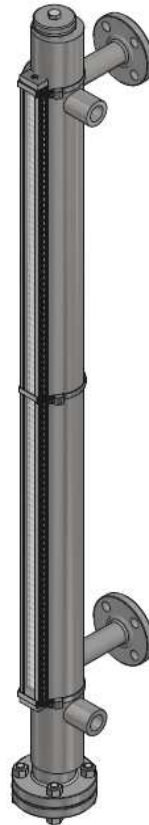

FIG.A



FIG.B

9. SPARE PARTS AVAILABLE UPON REQUEST(*)

POS.	DENOMINATION
1	BODY
2	BOLTING
(*)	GASKET
(*)	FLOAT
5	VISUAL RANGE
6	PLUG

Always mention the instrument serial number in your request for spare parts.

This number is provided on the instrument rating plate that is fastened to the bottom of the unit and is a five-digit number preceded by the letter "F" (e.g.:F45678).

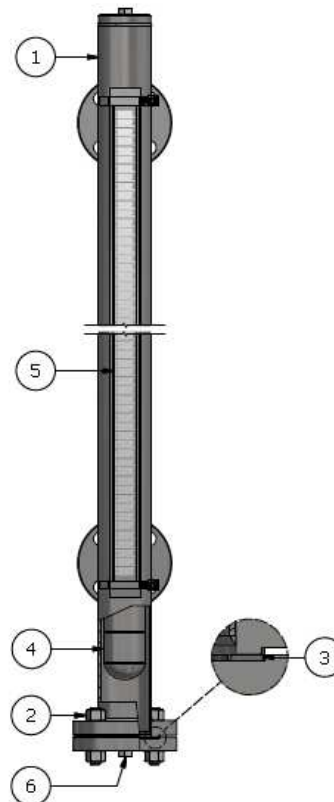



10. FAULT FINDING

Level indicators of the 2000 series are not normally exposed to faults.
In cases when the level indicator does not correctly detect the level, carry out the test on the dislocator, as indicated in paragraph 7, MAINTENANCE.

11. DISPOSAL

Once the level switches have reached the end of their working life, they should be sent for disposal in accordance with prevailing regulations.
During their disposal, pay special attention to the polymers, resins and rubber used in their construction (PVC, PTFE, PP, PVDF, neoprene, viton etc.).
Metal components may be recycled after removing the gaskets, special coverings as requested by the customer or other plastic materials.

12. GUARANTEE

All the parts of series 2000 level indicators are guaranteed to be free from manufacturing faults over a period of 12 months from the date of shipment.
In the event of a malfunction, if the defective part is returned within the above-mentioned warranty period, Officine Orobiche undertakes to replace any damaged parts under warranty (excluding transport costs), provided that the defect is not the result of the improper use of the instrument.
Officine Orobiche may not be held liable for any improper use of its products where these are used for ends other than those indicated in the specifications forming part of the order.
No claims for damages will be accepted in the case of improper use.
Damages and/or expenses, whether direct or indirect, arising from improper installation or use of the instrument shall not be attributable or debited to Officine Orobiche under any circumstance.
The instrument may be used for a maximum period of 10 years from the date of delivery.
After said period, the customer has two alternatives:
1) Replace the instrument with a new one.
2) Have the instrument overhauled by Officine Orobiche

HOW TO RETURN INSTRUMENTS

Any returned instruments must be accompanied by a sheet indicating:
1) The name of the customer
2) A description of the material
3) Details of the fault
4) Process data
5) Liquids with which the instrument has come into contact
The returned instrument must be perfectly clean, free of dust and deposits; otherwise, Officine Orobiche may reserve the right to refuse to carry out the required maintenance and return the item "as found" to the customer.

FINAL NOTES

Every instrument is supplied fully assembled with all the accessories requested by the customer.
Only in exceptional cases will the various components be supplied separately.
We therefore recommend that the customer inspects the delivery on arrival and immediately notifies Officine Orobiche of any discrepancies.

N.B. IN CASES WHEN THE INSTRUMENTS ARE MEANT TO BE USED IN AREAS FEATURING POTENTIALLY EXPLOSIVE ATMOSPHERES, THE USER SHALL COMPLY WITH THE ADDITIONAL SAFETY INSTRUCTIONS ATTACHED TO THE STANDARD ONES.