

**USER'S MANUAL FOR LEVEL SWITCHES
of the electrical SERIES 40**

1. INSTRUMENT DESCRIPTION

The instruments of the 40 series are positive buoyancy level switches for mounting on vessel head. They are equipped with various switching units to provide independent alarm and/or signalling contacts. Model 41A provides a low or high-level alarm contact. Model 41B is designed for pump control. Model 41C is equipped with two independent alarm contacts. Model 41D/1 is designed to control two pumps, of different capacity. For instance, to allow a vessel to remain full, if the level lowers, the first (small) pump will be actuated, but if the level continues to fall, the second (large) pump will be started. The large pump will be started and stops under the small pump's threshold. The instrument can even be used to keep a tank empty, in which case the operation of the two pumps is reversed. Even model 41D/2 manages two pumps. It is used to drain a vessel. In this case, the two pumps start at different levels but both only switch off after the level has reached the lower displacer. Model 41D/3 combines the pump start and stop functions with a low-level alarm. Model 41D/4 combines the pump start and stop function with a high-level alarm. The instrument 41D/5 manages two pumps. It is only used to fill a tank. In this case, the two pumps start at different levels but both only switch off after the level has reached the upper displacer. The instruments are designed to be mounted on top of pressure vessels, in a vertical position. The adjustment of the operation points takes place by adjusting the position of the displacers along the instrument's rope. The models can be equipped with SPDT or DPDT exchange contacts for a low or high-level control and/or alarm; the contacts can be electric or pneumatic in type.

2. MODEL IDENTIFICATION

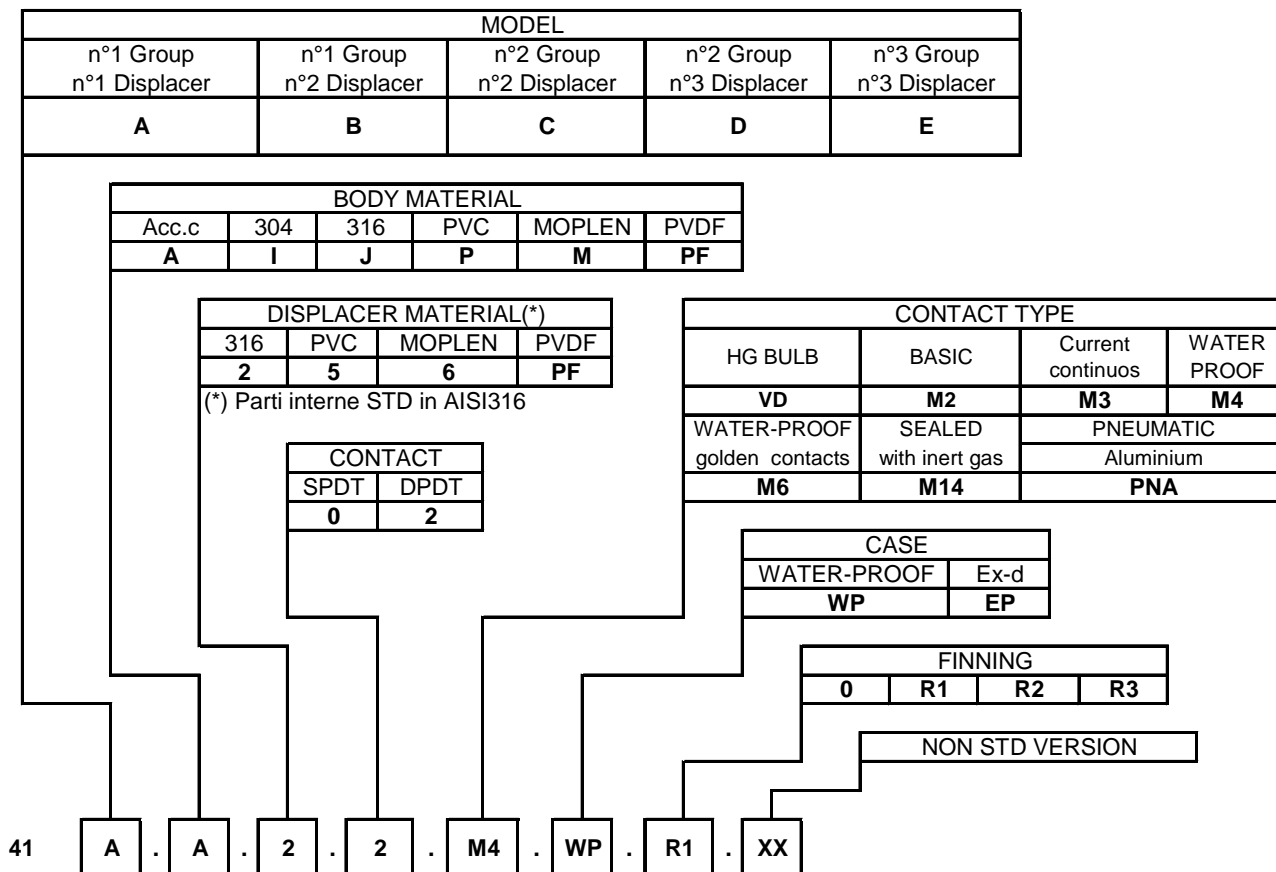

3. OPERATING PRINCIPLE

The operating principle is displacer-based. The displacer (1), partially or thoroughly immersed in the liquid, undergoes a hydrostatic thrust that reduces the load on the spring (6) which, being connected to a rod, pushes a small magnetic piston upwards (2). On the pit (3), one or more tripping units are mounted, which is schematised in the diagram, composed of a magnet (4) and a miniature switch (5) that are connected to one another by means of levers. In low level "A" condition, the magnet (4) is idle, in the high level "B" condition, the magnet (4) is drawn by the piston (2), and this causes the actuation of the miniature switch (5).

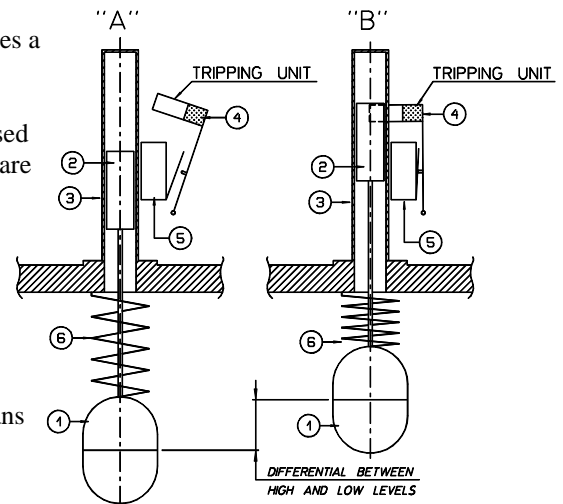

The difference in height between low level and high level of the fluid is called "tripping differential".

The connection between the spring and the displacer is performed by means of a rope. By moving the displacer along the rope, the tripping position changes.

4. INSTALLATION

4.1 FITTING ON THE SYSTEM

Before installing the unit, check the vessel connections and those of the instrument for compatibility. Burdening the instrument with external loads is strictly forbidden and it is the user's duty to protect it from stress; using the system as a rest point is strictly forbidden. To avoid the effects of galvanic corrosion, no use of materials featuring different electrochemical potential is allowed. The user shall apply all the technical expedients that are aimed at safeguarding the unit from such occurrence. The system shall be equipped with the prescribed safety valve, to avoid overpressures that exceed the limit value. The instruments shall be installed in vessels equipped with stilling pipe/displacer guide (A). Before actuating the instrument, ensure that the stilling Tube is perfectly upright and has a diameter that suits the displacer (about 5 mm of air around the displacer). Ensure that the connection to the tank is horizontal And perpendicular to the stilling pipe. Adjust the rope length to that of the vessel and Place the displacer at the desired height. For installation on vessels that are exposed to strong vibration, please contact our customer service department.

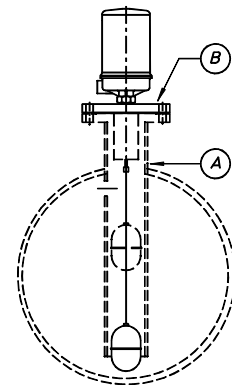

4.2 ELECTRICAL WIRING

The instrument is equipped with a terminal block located inside the housing. For connections (NC - C - NO), please refer to the drawing provided on this page. Make sure the housing lid is closed before injecting voltage. The user shall provide for suitable ground connections to protect the working staff and any other equipment possibly present.

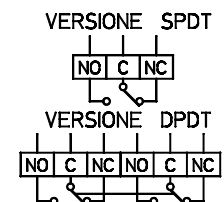

NO=NORMALLY OPEN
C=COMMON
NC=NORMALLY CLOSED

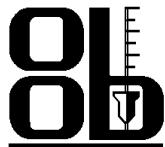

5. SETTING AT WORK

Make sure that the use of the instrument does not exceed the intended conditions of use (higher temperature and pressure values, lower specific weight) and that the applied electrical rated value complies with the rating plate values. Verify that the instrument operates a correct switchover, by making the fluid level vary a few times.

6. CALIBRATION

The adjustment of the tripping unit is performed by moving the displacer along the rope the instrument is equipped with. Ensure you have firmly locked the displacer before introducing it into the vessel.

No adjustment shall be made on the tripping unit, which is factory-set.

7. MAINTENANCE

We suggest carrying out a periodic routine servicing (once every 6 months approximately) to ascertain the correct service state of the instrument.

All maintenance actions need to be carried out when the instrument is depleted of pressure and fluid, at room temperature (in the event of units working at high or low temperature) and disconnected from the contact feeding voltage.

7.1 WARNINGS

- NEVER open the lid without being sure that voltage has been discontinued;
- NEVER leave the case without its lid for longer than the inspection time;
- NEVER use the instrument at a temperature or a pressure that exceeds the values specified on the rating plate;
- NEVER use the instrument at an electrical rating that exceeds the value specified on the rating plate;
- NEVER perform settings or replace parts without having read the instructions beforehand; in case of doubts, please contact our customer service department;
- NEVER lubricate any part of the instrument;
- In cases when the instrument is used at high temperature values, always take all the precautionary measures required to safeguard the working staff during the maintenance work stages.

7.2 ROUTINE CHECKS ON THE DISPLACER

Ensure the vessel is drained of all liquid.

- Separate the instrument from the vessel by unscrewing the related bolts.
- Extract the displacer by lifting the body flange (take care not to spoil or damage the rod, the displacer and the spring);
- Inspect the stilling tube and check it is clean from incrustation and/or deposit (if any such deposits are found, perform a thorough cleaning);
- Remove the union and take care not to fold the rod;
- Inspect the pit inside making sure it is free from incrustation (clean with care if necessary);
- Place the union back in place;
- Ensure that the displacer, the rod and the spring are free from incrustation (carefully clean, if necessary);
- Manually lift and lower the spring unit, and check that the whole set can freely slide;
- If the spring shows corrosion marks, replace the parts;

7.3 REPLACING THE DISPLACER AND/OR THE ROPE

After pulling the displacer out (see par.7.2), hold the damaged displacer in place, unscrew the screw that locks it to the rope. Place the new displacer, remember to lock it tightly to the rope.

If the rope shows marks of breaks, it needs replacing, by unscrewing the screw that locks it to the instrument.

The new rope, if too long, needs to be cut at the required length.

Remember to tightly lock the new rope before fitting the instrument back in place.

Perform all the checks as mentioned in paragraph 7.2.

7.4 ROUTINE CHECKS ON THE CONTACTS

Discontinue the voltage supply.

With the lid open, perform a sight check to ensure that the tripping unit does not have damaged or aged parts, manually actuate the magnet to test whether the miniature switch correctly performs the switchover.

7.5 REPLACING THE ASSEMBLY AND/OR MINIATURE SWITCH

- Use a gauge to measure the position of the switching unit;
- Remove the wires from the terminal block (note the original connections), by loosening the screw (2) and remove the switching unit;
- Replace the miniature switch (1);
- Place the switching unit back on top of the pit (3), in the same position as measured before;
- Perform the tripping adjustment by manually positioning the magnet (4) against the pit (3), screw on the grub-screw (5) until the miniature switch triggers and provide an over stroke turn before tightening the grub-screw;
- Check miniature switch (1) for proper operation by means of an ohmmeter and carry out some manual trip tests.
- Reconnect the wires back into the terminal block as in b) above.

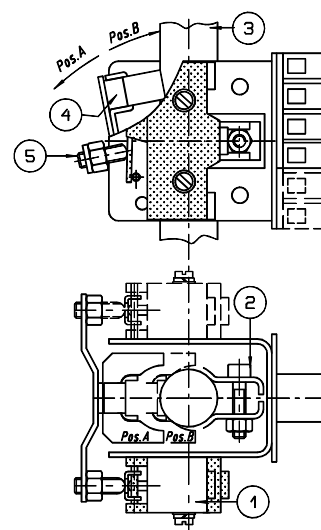

7.6 SETTING THE OPERATION POINT

See paragraph (6) CALIBRATION

8. DIMENSIONAL DRAWINGS OF THE BODY

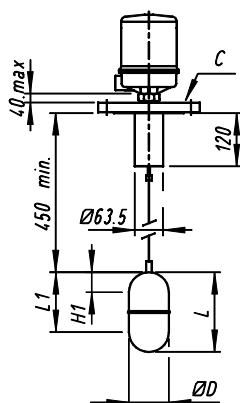

Model 41A metallic

C	ØDxL	P.S.	0.6	0.65	0.7	0.75	0.8	0.85	0.9	0.95	1.0
4" – DN100	94x180	H1	75	80	90	95	100	100	105	105	110
		L1	120	125	130	135	135	135	140	140	140
3" – DN80	76x240	H1	100	110	120	120	125	135	140	150	150
		L1	160	170	175	175	185	185	185	190	190

C	ØDxL	P.S.	1.0	1.05	1.1	1.15	1.2	1.25	1.3	1.35	1.4
4" – DN100	94x180	H1	110	110	115	115	120	120	125	125	125
		L1	140	140	145	145	150	150	150	150	150
3" – DN80	76x240	H1	145	150	150	155	160	160	165	165	165
		L1	185	190	190	190	195	195	200	200	200

Model 41A plastic

C	ØDxL	P.S.	0.5	0.7	0.9	1.1	1.3
4" – DN100	90x200	H1	83	116	135	146	154
		L1	146	164	174	181	185
3" – DN80	75x290	H1	119	167	194	211	223
		L1	206	232	247	256	262

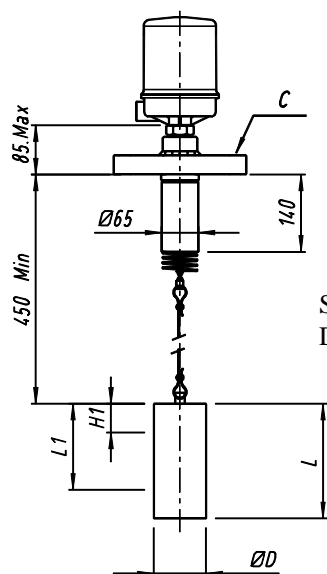

STD rope length = 3 m

Dimensional values to be specified on the order: C = Connection flange

D/L = Displacer size

H/L = Operation points as from the displacer's top

Model 41B metallic

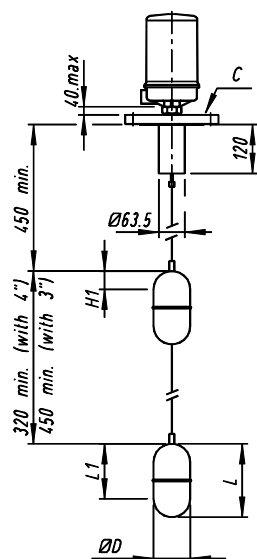

C	ØDxL	P.S.	0.8	0.85	0.9	0.95	1.0
4" – DN100	94x180	H1	100	100	105	105	110
		L1	135	135	140	190	140
3" – DN80	76x240	H1	125	135	140	150	150
		L1	185	185	190	190	190

STD rope length = 3 m

Dimensional values to be specified on the order: C = Connection flange

D/L = Displacer size

H/L = Operation points as from the displacer's top

Model 41B plastic

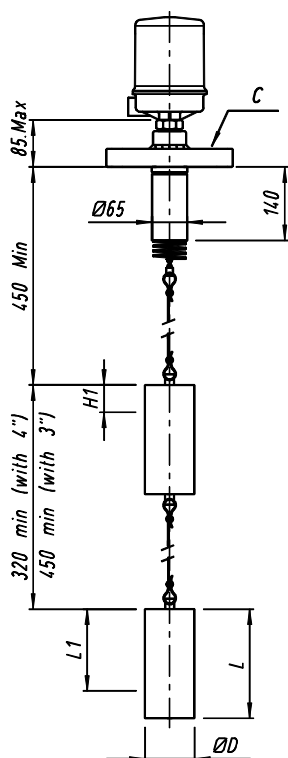

C	ØDxL	P.S.	0.80	0.85	0.90	0.95	1.0
4" – DN100	90x150	H1	64	78	90	101	111
		L1	136	139	142	144	146
3" – DN80	75x215	H1	90	109	126	142	155
		L1	177	181	184	188	190

STD rope length = 3 m

Dimensional values to be specified on the order: C = Connection flange

D/L = Displacer size

H/L = Operation points as from the displacer's top

Model 41C metallic

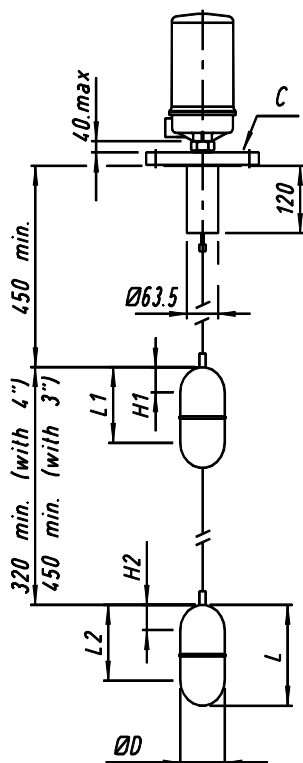

C	ØDxL	P.S.	0.78	0.8	0.83	0.85	0.85	0.9	0.95	1.0
4" – DN100	94x180	H1	63	70	78	84	65	75	85	100
		L1	120	125	132	136	115	125	135	150
		H2	87	89	92	94	85	90	95	100
		L2	134	135	136	137	130	135	135	140
3" – DN80	76x240	H1	82	90	103	110	80	100	115	135
		L1	157	164	174	180	150	165	180	195
		H2	115	118	122	124	115	120	130	135
		L2	176	178	180	181	175	175	180	185

C	ØDxL	P.S.	1.0	1.05	1.1	1.15	1.2	1.25
4" – DN100	94x180	H1	60	70	80	90	100	110
		L1	105	115	125	125	140	150
		H2	60	65	70	75	80	80
		L2	100	105	105	110	115	115
3" – DN80	76x240	H1	75	90	105	120	135	145
		L1	135	150	165	175	185	195
		H2	80	85	95	100	105	110
		L2	130	135	140	145	150	155

STD rope length = 3 m

Dimensional values to be specified on the order: C = Connection flange

D/L = Displacer size

H/L = Operation points as from the displacer's top

Model 41C plastic

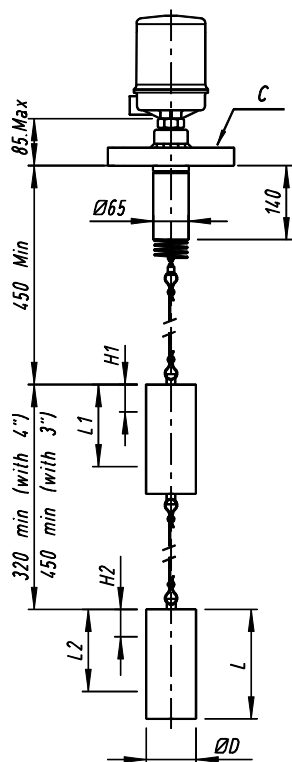

C	ØDxL	P.S.	1.0	1.1	1.2	1.3
4" – DN100	90x200	H1	55	86	112	134
		L1	107	135	158	177
		H2	46	60	71	81
		L2	90	101	110	118
3" – DN80	75x290	H1	79	150	162	194
		L1	150	190	223	251
		H2	66	86	148	197
		L2	125	141	154	165

STD rope length = 3 m

Dimensional values to be specified on the order: C = Connection flange

D/L = Displacer size

H/L = Operation points as from the displacer's top

Model 41E metallic

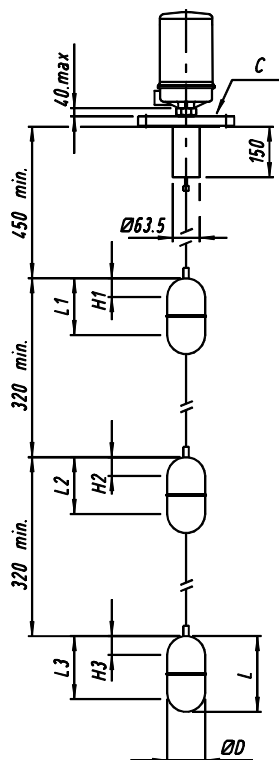

C	ØDxL	P.S.	1.0
3" - DN80	76x170	H1	60
		L1	120
		H2	70
4" - DN100		L2	125
		H3	70
		L3	115

STD rope length = 3 m

Dimensional values to be specified on the order: **C** = Connection flange

D/L = Displacer size

H/L = Operation points as from the displacer's top

Model 41E plastic

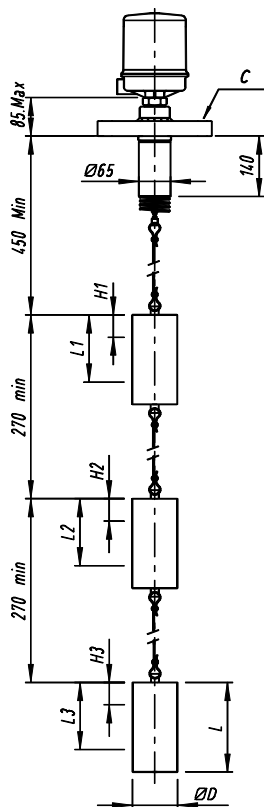

C	ØDxL	P.S.	1.0
3" - DN80	75x150	H1	51
		L1	113
		H2	54
4" - DN100		L2	109
		H3	60
		L3	104

STD rope length = 3 m

Dimensional values to be specified on the order: **C** = Connection flange

D/L = Displacer size

H/L = Operation points as from the displacer's top

Model 41D metallic

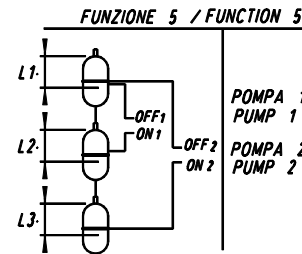
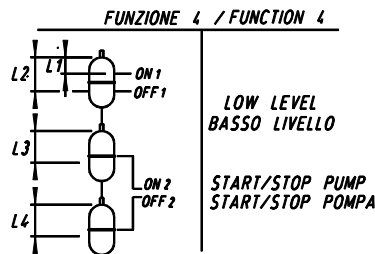
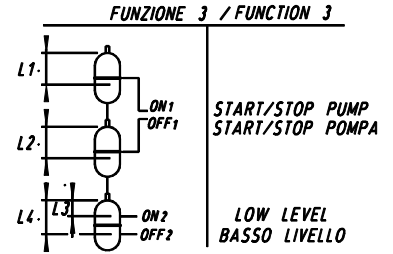
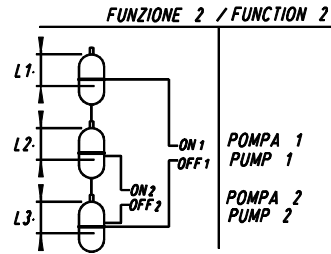
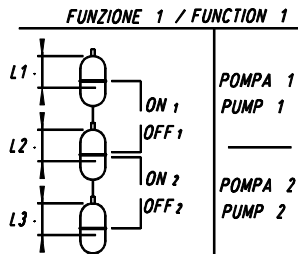
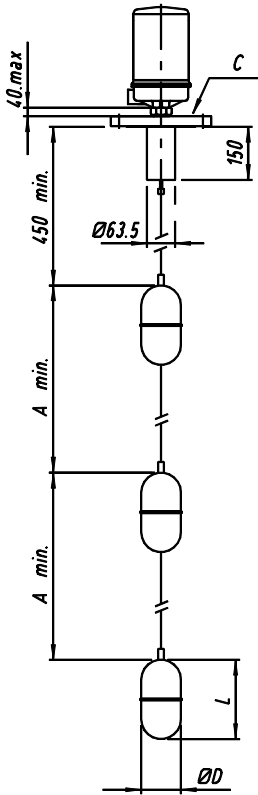

C	DxL	Function 1			Function 2			Function 3				Function 4				Function 5		
		L1	L2	L3	L1	L2	L3	L1	L2	L3	L4	L1	L2	L3	L4	L1	L2	L3
3" - DN80	76x240	105	103	106	--	--	--	105	103	78	143	87	174	85	93	--	--	--
4" - DN100	94x180	63	61	42	--	--	--	63	61	44	94	68	133	67	75	--	--	--
3" - DN80	76x170	--	--	--	78	78	88	--	--	--	--	--	--	--	--	78	88	88
4" - DN100		--	--	--	--	--	--	--	--	--	--	--	--	--	--	--	--	--

Note: A = 270 mm with Displacer 76x240

A = 210 mm with Displacer 76x170

A = 210 mm with Displacer 94x180

The operation points are calculated with specific weight = 1Kg/dcm³

STD rope length = 3 m

Dimensional values to be specified on the order: C = Connection flange

D/L = Displacer size

H/L = Operation points as from the displacer's top

Model 41D plastic

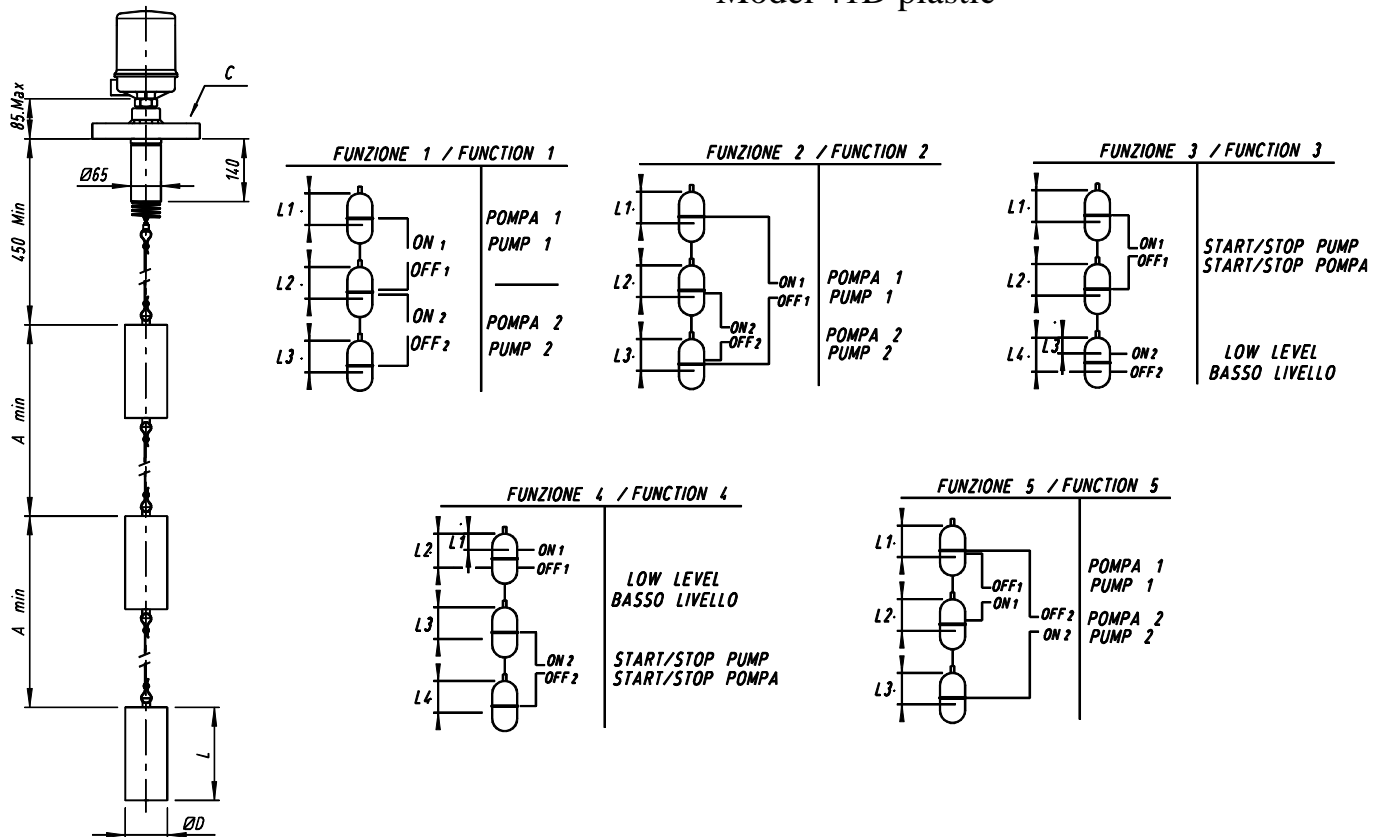

C	DxL	Function 1			Function 2			Function 3				Function 4				Function 5		
		L1	L2	L3	L1	L2	L3	L1	L2	L3	L4	L1	L2	L3	L4	L1	L2	L3
3" - DN80	75x215	131	129	112	--	--	--	131	129	104	170	75	164	72	80	--	--	--
4" - DN100	90x150	91	90	81	--	--	--	91	90	72	122	52	117	50	59	--	--	--
3" - DN80	75x150	--	--	--	68	68	78	--	--	--	--	--	--	--	--	68	78	78
4" - DN100																		

Note: A = 270 mm with Displacer 76x240
 A = 210 mm with Displacer 76x170
 A = 210 mm with Displacer 94x180

The operation points are calculated with specific weight = 1Kg/dcm³
 STD rope length = 3 m

Dimensional values to be specified on the order: **C** = Connection flange
D/L = Displacer size
H/L = Operation points as from the displacer's top

9. DIMENSIONAL DRAWINGS OF THE HOUSING

CODE	FLUID TEMPERATURE
Ø	-10÷+135
R3	-11÷-80
R1	+136÷+250
R4	+251÷+400

ELECTRICAL CONNECTIONS Ø A	
EP	WP
1/2" NPT	1/2" NPT
3/4" NPT	3/4" NPT
1/2" UNI 6125	1/2" (GAS) ISO 228/1
3/4" UNI 6125	3/4" (GAS) ISO 228/1
ISO M20 x 1.5	1/2" UNI 6125
	ISO M20 x 1.5

EP HOUSING (EEx-d IIC T6)

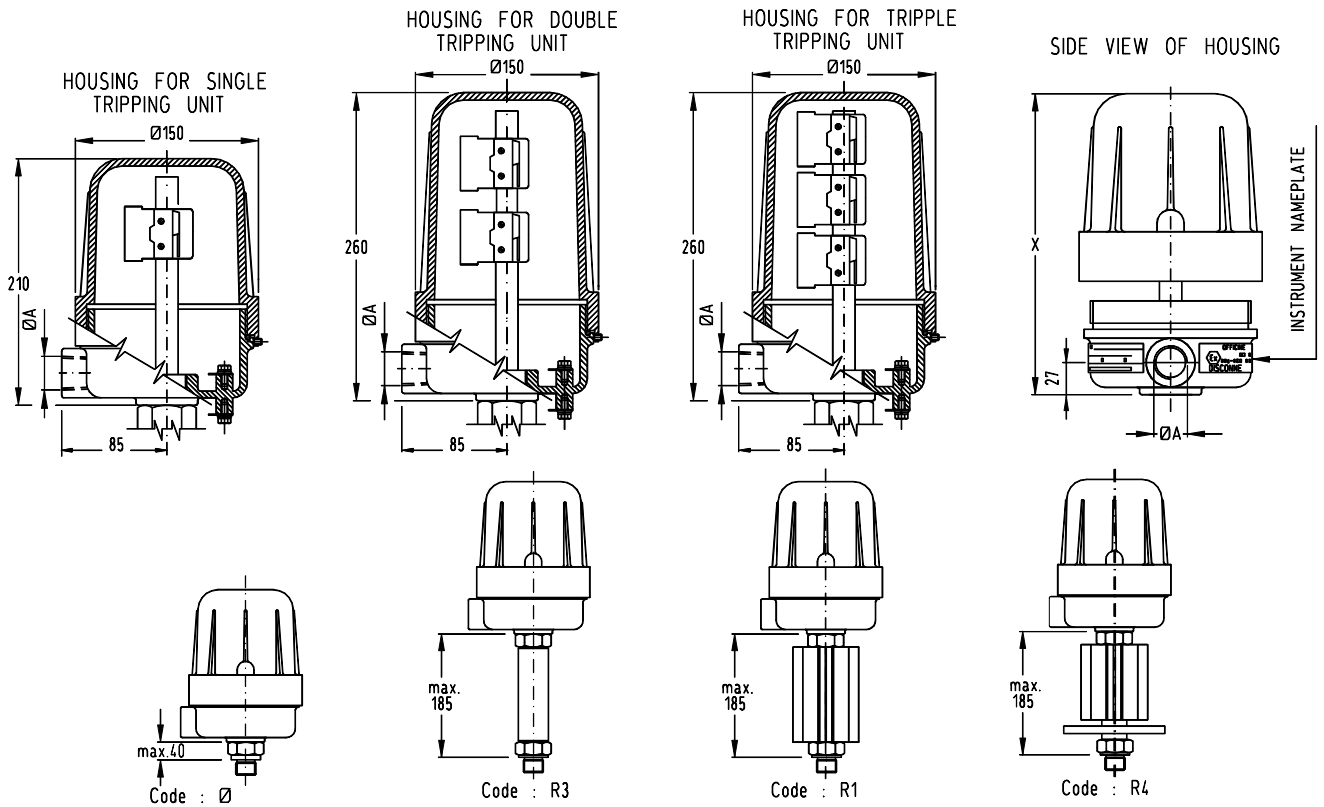

SPACE REQUIRED TO DISMOUNT HOUSING COVER : X = 340 HOUSING WITH SINGLE TRIPPING UNIT
 X = 440 HOUSING WITH DOUBLE TRIPPING UNIT
 X = 440 HOUSING WITH TRIPPLE TRIPPING UNIT

WP HOUSING (WATER PROOF IP66)

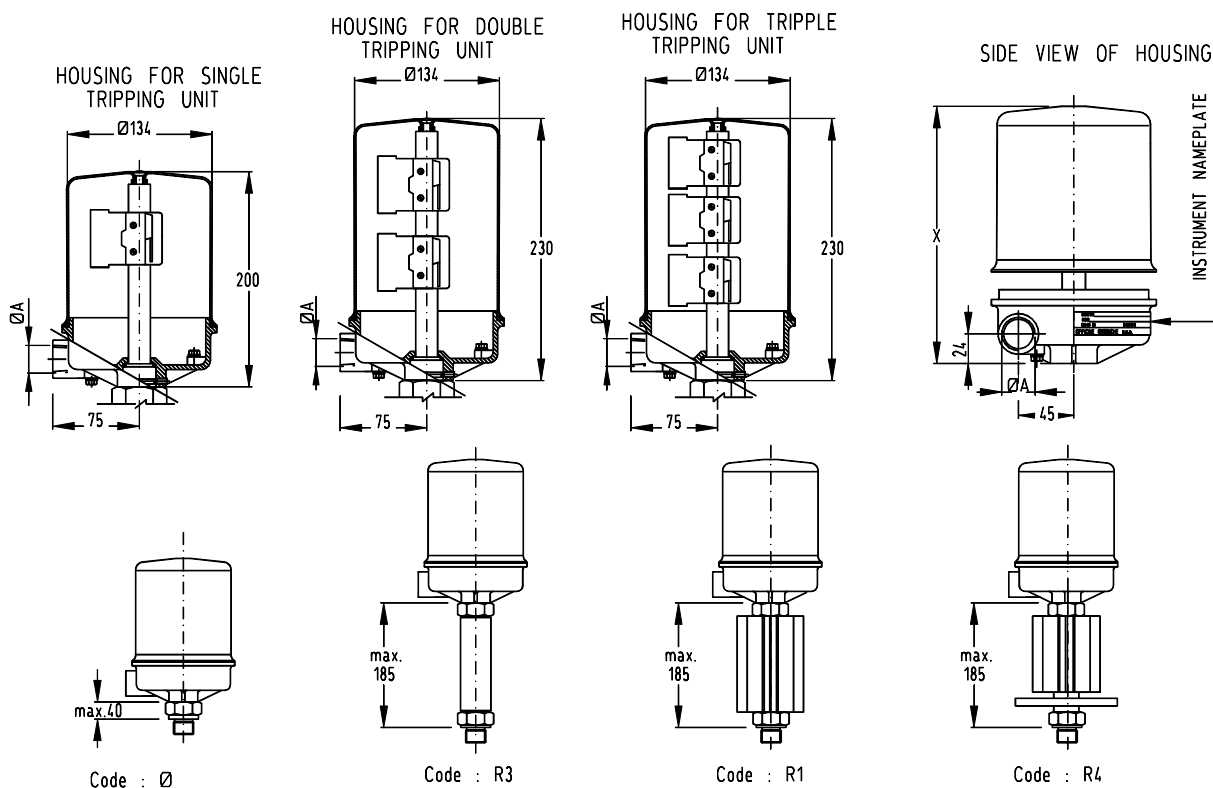

SPACE REQUIRED TO DISMOUNT HOUSING COVER : X = 320 HOUSING WITH SINGLE TRIPPING UNIT
 X = 400 HOUSING WITH DOUBLE TRIPPING UNIT
 X = 400 HOUSING WITH TRIPPLE TRIPPING UNIT

WP HOUSING (WITH CONNECTOR OUTPUT)

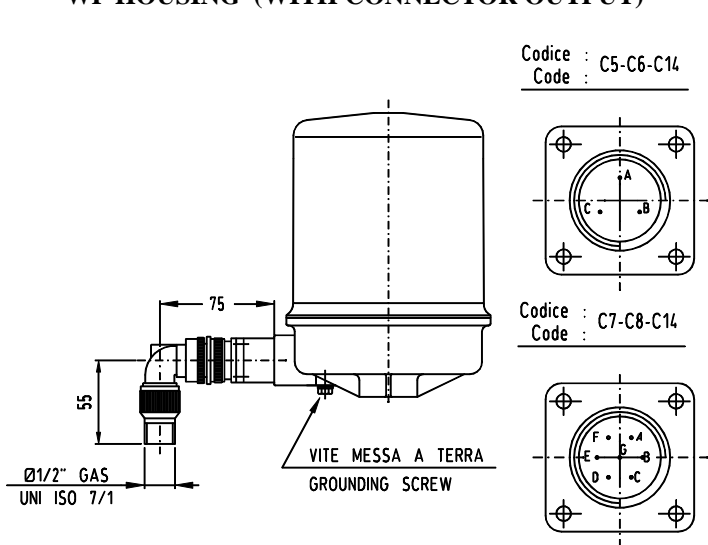

CONTATTO SPDT SPDT CONTACT							
	A	B	C	D	E	F	G
41A	NO	NC	C				
41B	NO	NC	C				
41C	NO	NC	C	NO	NC	C	(*)
41D	NO	NC	C	NO	NC	C	(*)

NOTA: (*) TERRA/GROUNDING

10. RECOMMENDED SPARE PARTS (*)

POS	DESCRIPTION
	1 Flange body
	2 Spring protector
(*)	3 Displacer
	4 Union
(*)	5 Gasket
	6 Spring retainer
(*)	7 Rope
	8 Screws
	9 Spring assembly
(*)	10 Switch unit
(*)	11 Micro switches
	12 Instrument nameplate
	13 External grounding unit
	14 Internal grounding unit
(*)	15 Housing gasket
	16 Housing base
	17 Housing cover
	18 EP housing cover fastening group screw
	19 WP housing base fastening group screw
	20 WP housing cover fastening group screw

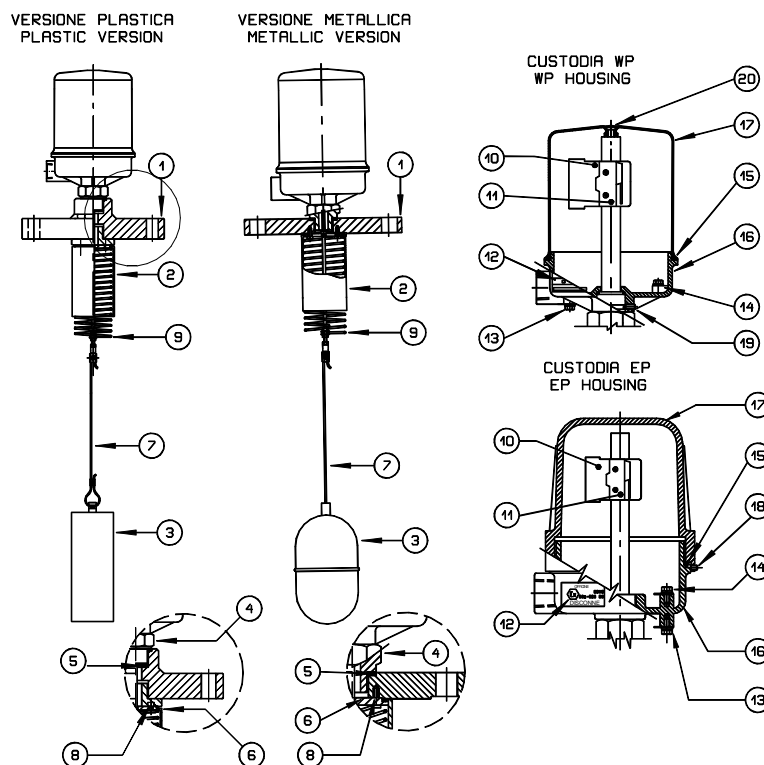

Always mention the instrument serial number in your request for spare parts.

This number is provided on the instrument rating plate that is fastened to the housing (see Pos.12) and is a five-digit number preceded by the letter "F"(e.g.: F45678).

11. FAULT FINDING

Level switches of the 40 series are not normally exposed to faults.

In cases when the level switch does not operate the switching, carry out the test on the displacer and on the miniature switch as indicated in paragraph 7. MAINTENANCE.

12. DISPOSAL

When the instruments have come to the end of their service life, they need to undergo disposal. Always comply with the applicable regulations in force.

During the disposal stages, specially mind the polymers, resins and rubbers used in the manufacture (PVC, PTFE, PP, PVDF, neoprene, viton, etc.).

All metal parts, after the removal of seals and gaskets, special protective coatings requested by the customer and all other plastic parts, can be recycled.

WARNING:

If the installed miniature switches are of the mercury bulb type (code VD), they must undergo disposal in compliance with the regulations currently in force for harmful poisonous materials. Other types of miniature switches are not subject to these regulations.

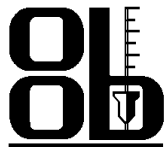

13. GUARANTEE

All the switches parts of the 40 series are guaranteed to be free from manufacturing faults over a period of 12 months from the date of shipment.

In the event of failures, implying return of goods within the limit specified above, OFFICINE OROBICHE will replace (shipment fees not included) all damaged parts free, provided that the failure does not ensue from incorrect use.

OFFICINE OROBICHE shall never be held responsible for any incorrect use of their products when these are used for purposes other than those mentioned in the specifications approved at the order stage.

In these cases, no complaints will ever be taken into consideration.

No damage and/or fee, whether direct or indirect, ensuing from an incorrect installation or use shall ever be debited to OFFICINE OROBICHE.

The instrument can be used for a maximum life period of 10 years dating from delivery.

When this period is over, there are two alternative options:

- 1) Replace it with a new instrument.
- 2) Have the old instrument overhauled by OFFICINE OROBICHE.

INSTRUMENT RETURN PROCEDURE

The instrument returning to the factory shall bear, in attachment, the following data:

- 1) Buyer's name.
- 2) Description of the material.
- 3) Detected fault.
- 4) Process data.
- 5) Specification of the fluids that have been used with the instrument.

The instrument shall be returned perfectly clean and free from dust or deposits. Otherwise, OFFICINE OROBICHE reserve the right not to carry out the servicing and return the instrument to the sender.

FINAL REMARKS

Each instrument is supplied fully assembled and equipped with all the needed accessories.

Some parts are sold separately under special circumstances only.

Therefore, we warn you to carefully inspect the supply and notify us at once if discrepancies are found.

N.B. IN CASES WHEN THE INSTRUMENTS ARE MEANT TO BE USED IN AREAS FEATURING POTENTIALLY EXPLOSIVE ATHMOSPHERES, THE USER SHALL COMPLY WITH THE ADDITIONAL SAFETY INSTRUCTIONS ATTACHED TO THE STANDARD ONES.