

RESISTIVE LEVEL GAUGE ELG Series



DESCRIPTION

The Resistive Level Gauge ELG Series is designed to give a clear level indication in tanks and boilers in high temperature and pressure conditions.

It consists in a bypass chamber made of steel (ELG-C) that has inside some probes (ELG-P). The probe can detect the presence of liquid or steam and transmits it to a control unit (ELG-E). The control unit indicates the liquid level with and LED for each probe that can turn green in case of liquid and red in case of steam.

The ELG-P probes detects the presence of water or steam by measuring the fluid conductivity with two metallic parts, isolated by a ceramic one.

As an accessory, the instrument can be supplied with one or more remote indication units (ELG-R).



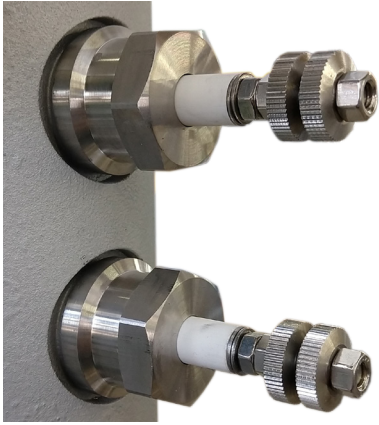

FEATURES

- Suitable for high temperature and pressure conditions.
- Clear level indication with switch option.
- The redundant double processor design gives the maximum reliability.
- Complete production control fully integrated inside the company and highly competent local suppliers.
- Qualified welders and welding procedures compliant with ASME IX and EN ISO 15614.
- Designed compliant with ASME-Boiler and EN standard.
- Completely customizable on client's needs thanks to the support of our technical and sales departments.
- Over 60 years company experience with instruments installed in the entire world.
- Long working life ensured by high quality materials.

TECHNICAL SPECIFICATIONS

- Probes steps constant or customized, minimum 50 mm
- Up to 20 probes and more on request
- Pressure up to 220 barg and over on request
- Temperature up to 374 °C and over on request
- Double 4-20 mA output signal for connection with a DCS or a remote unit
- Power supply 100/240 V AC, 24 V DC, 40 W for single or 2 x 20 W for double
- SPDT alarm relay, max. 48 V DC, 1 A
- One LED for each probe that can turn green if the probe detects liquid, red if the probe detects steam
- Backlit 128x64 LCD display that indicates alarms or malfunctions
- 8 additional LED that show the normal operating or the level alarms
- Chamber in SS316/316L, carbon steel and other materials on request
- On request standard Officine Orobiche paintings or compliant with client specifications

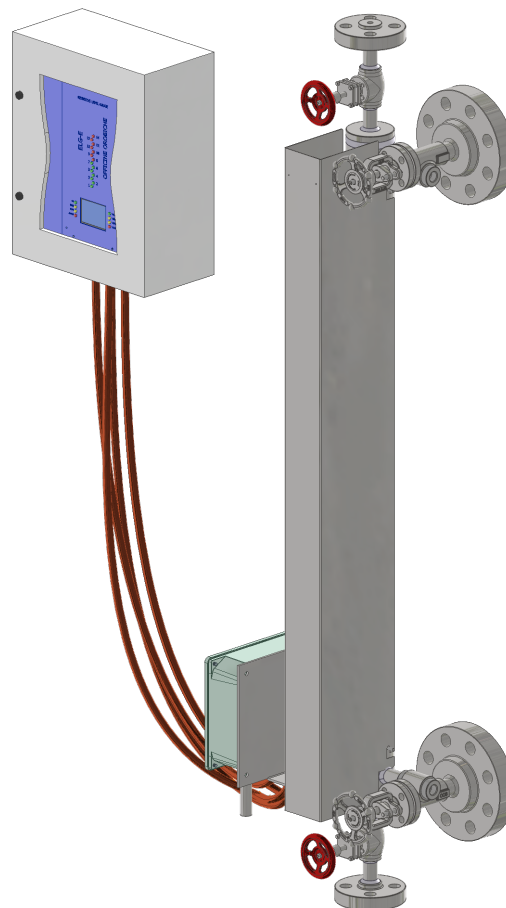

CONNECTIONS

The Level Gauge ELG Series is available with the following process and drain/vent connections:

- **Flanged**
 - ANSI B16.5
 - EN 1092/1
- **Threaded**
 - NPT-F ○ NPT-M
 - GAS-F ○ GAS-M
- **Weld stub**
 - SW - socket weld
 - BW - butt weld

The instrument is available with different connection positions:

- Side - Side
- Side - Side Right
- Side - Side Left
- Side - Bottom
- Top - Side
- Top - Bottom

Different connections layout are available on request, like for example with three Side connection.

On request the flanges can be welding neck type with full penetration welds.

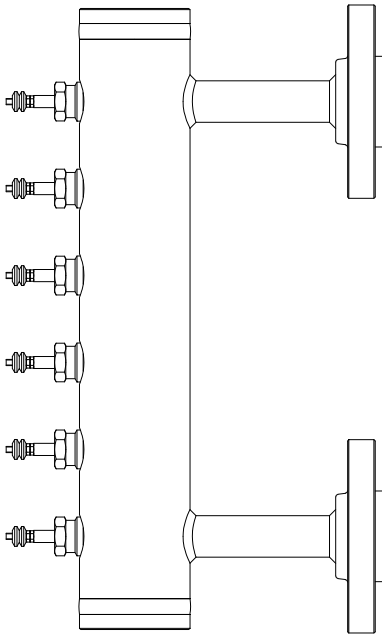

Side - Side

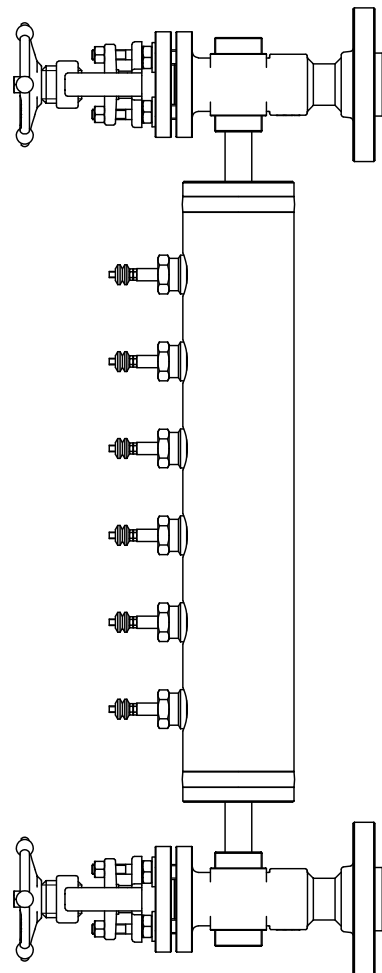

Side - Side with YY valves

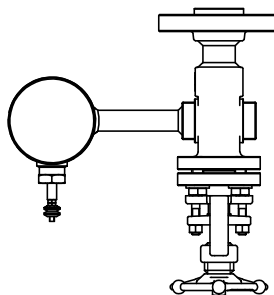
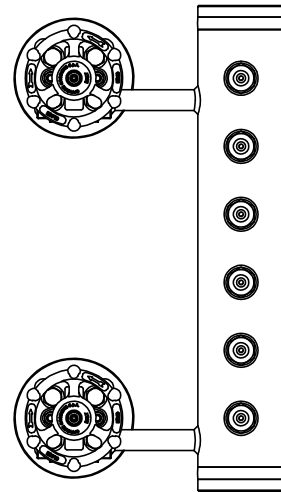
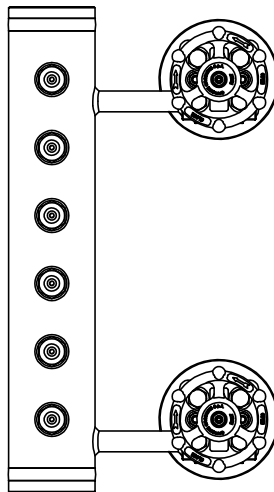

Side - Side Right

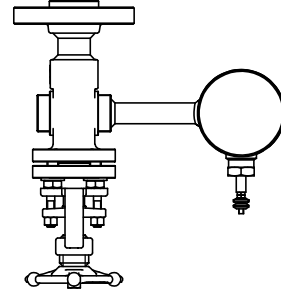

Side - Side Left

VALVES

As accessory the Level Gauge ELG Series can be supplied with shut-off, drain or vent valves. The valve type is chosen depending on the design temperature and pressure.

Shut-off:

- Cock type NY (PN100)
- Off-set OS&Y type YY (PN250)
- Globe type for high temperature and pressure
- Gate type for high temperature and pressure

Drain / Vent

- Needle type for high temperature and pressure
- Globe type for very high temperature and pressure
- Gate type for very high temperature and pressure

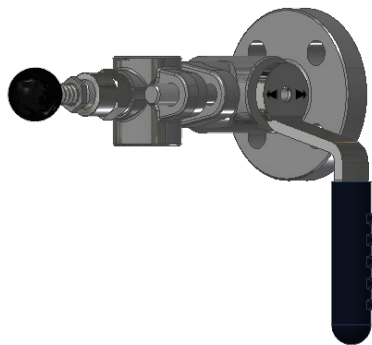

Flanged NY Valve

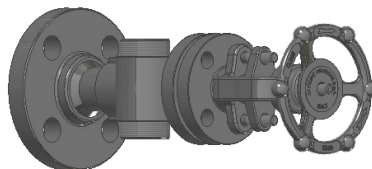

Flanged YY Valve

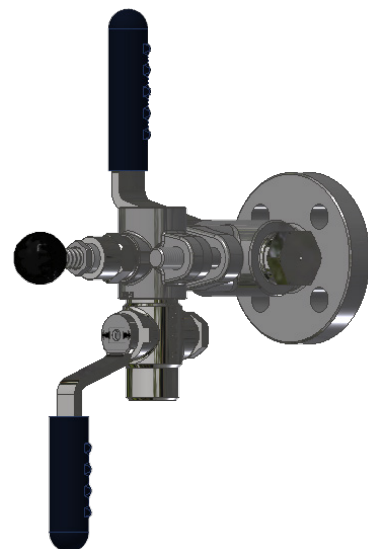

NY valve with drain/vent valve

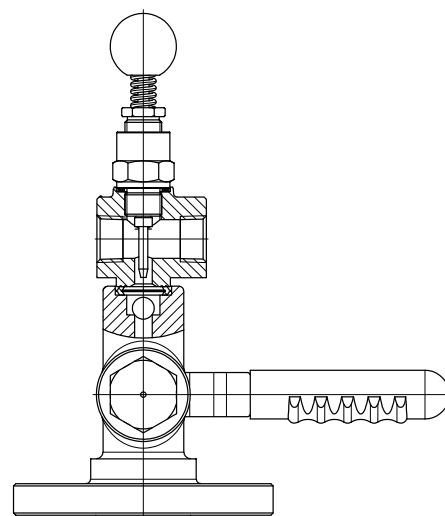
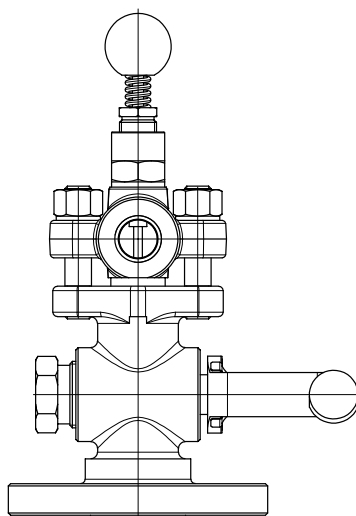

Cock valve NY with ball check

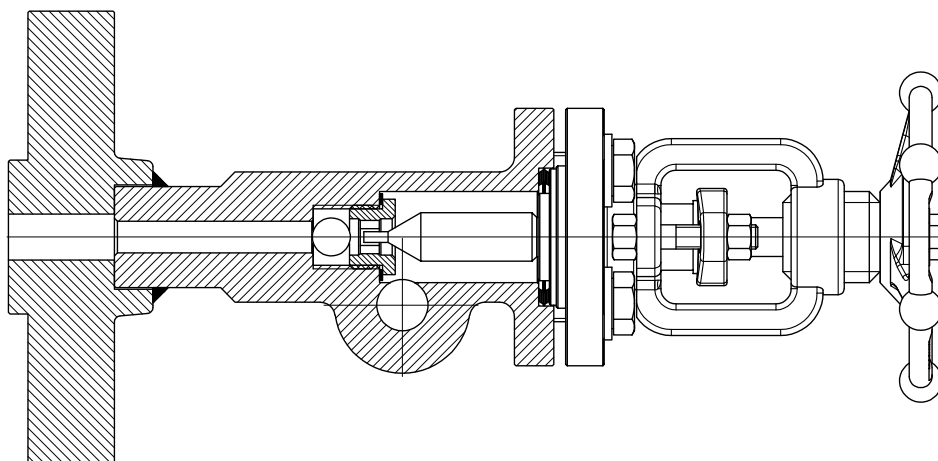

OS&Y type valve YY



ELG-E standard

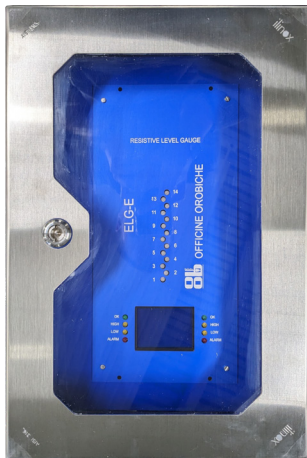

ELG-E SS316L



ELG-E explosion-proof IIB

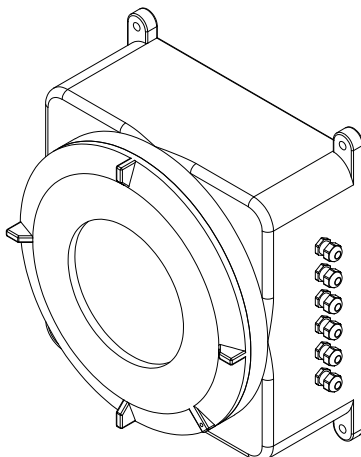

ELG-E explosion-proof IIC

ELG-E CONTROL UNIT

The control unit ELG-E is available with a plastic GRP housing or, on request, in explosion-proof version in die-cast aluminium.

The unit is divided in two sections:

- One analogic section detects the probes status and controls the relative LEDs turning them red in case of steam and green in case of liquid.
- One section comprehensive of two microprocessors, each with 4-20 mA output signal. This section includes also two SPST alarm relays for high and low level and it can show eventual malfunctions on the display.

The alarms are activated after 30 seconds in order to avoid false signals.

The double processor redundancy allows the correct operation even in case of one microprocessor malfunction.

The unit contains:

- One LED for each probe that turn red in case of steam and green in case of liquid
- Two green LED that are turned on in case of normal level
- Two yellow LED that are turned on in case of high level (settable)
- Two yellow LED that are turned on in case of low level (settable)
- Two red LED that are turned on if the high or low level is reached by two probes (settable)
- A LCD display that shows the probes status and eventual malfunctions

On request it's available a version with a 4-20 mA output to be connected to a further remote indicator or to a DCS.

For the safe area, all the housings and the junction box can be in SS316L.

ELG-R REMOTE UNIT

The ELG Series Level Gauge can be supplied with one or more remote indicators ELG-R, comprehensive of:

- 20 bicolor LEDs that turn from red to green proportionally to the 4-20 mA signal of ELG-E,
- A 7 segments, 3 ciphers display that shows in percentage the 4-20 mA signal of ELG-E,
- A red LED that is turned on in case of system error (when the ELG-E output is 3.5 mA).

The combination of Display and LED allows a clear and immediate level indication.

On request the remote indicator ELG-R is available in analogic + digital version that receive from ELG-E, in addition to the 4-20 mA signal, also a digital signal from the two microprocessor. This version includes in addition:

- 2 green LEDs, 4 yellow LEDs and 2 red LEDs that are turned on in the same way as the ELG-E ones,
- A green LED for each probe that are turned on when the probe detects liquid.

The remote indicator ELG-R comes with a die cast aluminium housing for safe area. On request it's available in SS316L or in explosion-proof version for classified area or mounted on a panel for the installation in control room.



ELG-R Standard

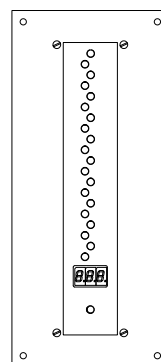

ELG-R panel version

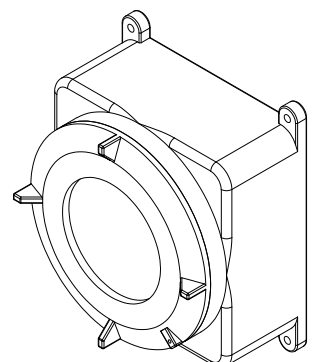

ELG-R explosion-proof IIC



APPROVALS

On request the following approvals are available:

- PED 2014/68 UE
- NACE MR-0175 e MR-0103

The housing is available with ATEX or IECEx explosion-proof approval Ex d.

MODEL CODE AND SPARE PARTS

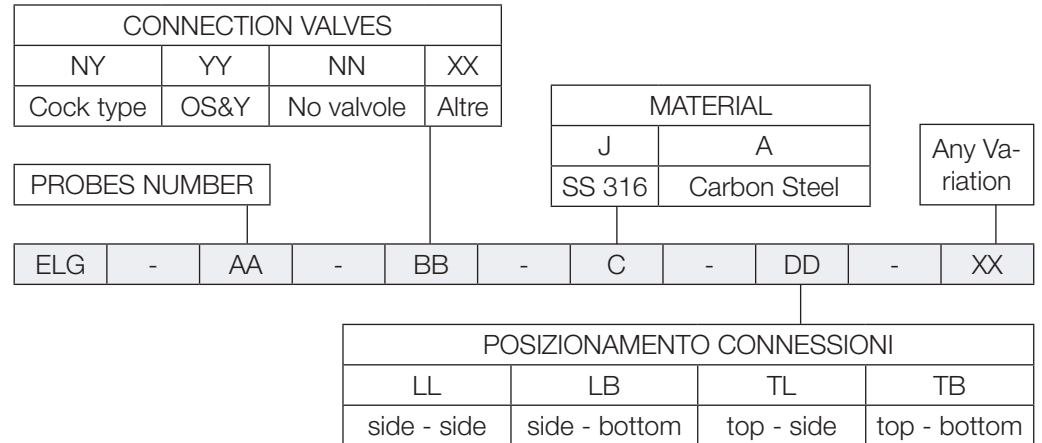

In order phase please state:

- Materials
- Operating and design conditions
- Connections range and connections type
- Number of probes and their step
- Any accessory needed

Our company database contains information about the instruments manufactured in 60 years, to request spare parts for an installed instrument state the F number written in the top-right of the label:



Our technical and commercial departments are available to discuss any variation or customization not mentioned in this catalogue.



Officine Orobiche S.r.l.

Via Paglia, 22 - 24050 Zanica (Bergamo) - Italy
Tel. +39 035 4530 211



www.officineorobiche.it
info@officineorobiche.it